



No.:

Date: 26-DEC-2012

Customer :

TECHNICAL PROPOSAL

Three-phase induction motor - Squirrel cage rotor

Product line : Three-Phase : Explosion Proof - NEMA Premium

Catalog Number : 00236XT3E145TC

List Price : \$1,045

Notes:

Performed by:

Checked:



No.:

Date: 26-DEC-2012

DATA SHEET

Three-phase induction motor - Squirrel cage rotor

Customer :
Product line : Three-Phase : Explosion Proof - NEMA Premium

Frame : 145T
Output : 2 HP
Frequency : 60 Hz
Poles : 2
Full load speed : 3495
Slip : 2.92 %
Voltage : 208-230/460 V
Rated current : 5.95-5.38/2.69 A
Locked rotor current : 50.6/25.3 A
Locked rotor current (I_L/I_n) : 9.4
No-load current : 2.60/1.30 A
Full load torque : 2.96 lb.ft
Locked rotor torque : 350 %
Breakdown torque : 400 %
Design : B
Insulation class : F
Temperature rise : 80 K
Locked rotor time : 15 s (hot)
Service factor : 1.15
Duty cycle : S1
Ambient temperature : -20°C - +40°C
Altitude : 1000
Degree of Protection : IP54
Approximate weight : 66 lb
Moment of inertia : 0.05505 sq.ft.lb
Noise level : 68 dB(A)

	D.E.	N.D.E.	Load	Power factor	Efficiency (%)
Bearings	6205 ZZ	6204 ZZ	100%	0.82	85.5
Regreasing interval	---	---	75%	0.76	84.0
Grease amount	---	---	50%	0.64	80.0

Notes:

Performed by

Checked



No.:

Date: 26-DEC-2012

PERFORMANCE CURVES RELATED TO RATED OUTPUT

Three-phase induction motor - Squirrel cage rotor

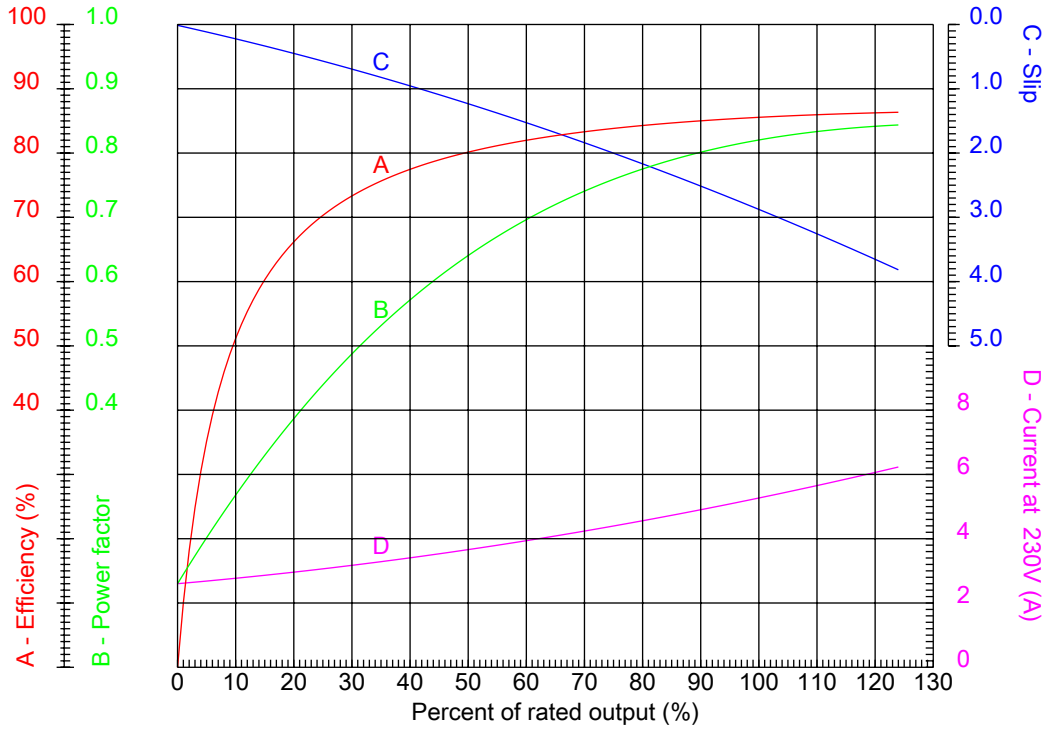

Customer :
 Product line : Three-Phase : Explosion Proof - NEMA Premium

Frame	: 145T	Locked rotor current (I _l /I _n)	: 9.4
Output	: 2 HP	Duty cycle	: S1
Frequency	: 60 Hz	Service factor	: 1.15
Full load speed	: 3495	Design	: B
Voltage	: 208-230/460 V	Locked rotor torque	: 350 %
Rated current	: 5.95-5.38/2.69 A	Breakdown torque	: 400 %
Insulation class	: F		

Notes:

Performed by

Checked



No.:

Date: 26-DEC-2012

CHARACTERISTIC CURVES RELATED TO SPEED

Three-phase induction motor - Squirrel cage rotor

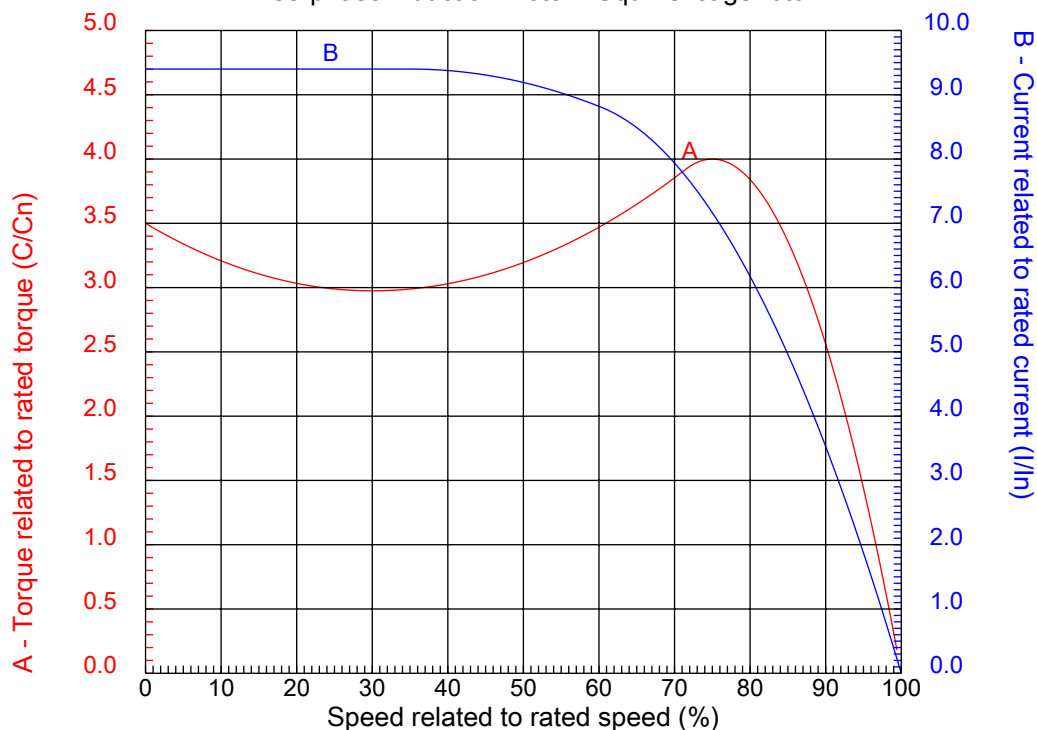

Customer :
Product line : Three-Phase : Explosion Proof - NEMA Premium

Frame	: 145T	Locked rotor current (I _l /I _n)	: 9.4
Output	: 2 HP	Duty cycle	: S1
Frequency	: 60 Hz	Service factor	: 1.15
Full load speed	: 3495	Design	: B
Voltage	: 208-230/460 V	Locked rotor torque	: 350 %
Rated current	: 5.95-5.38/2.69 A	Breakdown torque	: 400 %
Insulation class	: F		

Notes:

Performed by

Checked

1 2 3 4 5 6 7 8

A

B

C

D

E

F

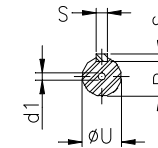
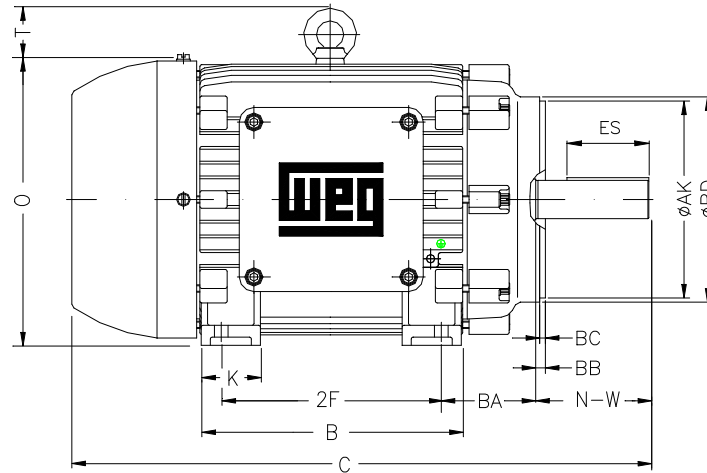
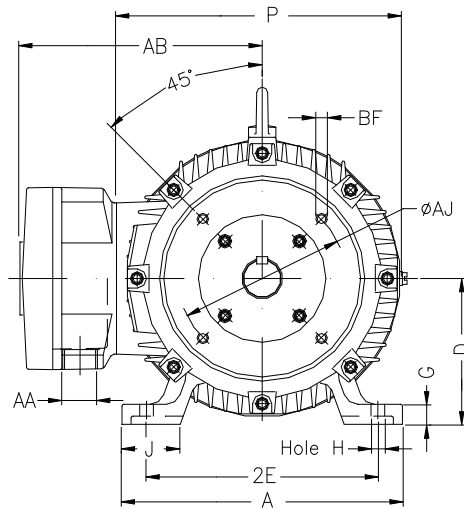

Notes:

Performed by:

Checked:

Customer:

Three-Phase : Explosion Proof - NEMA Premium

Three-phase induction motor
Frame 145T - IP54

26-DEC-2012



2E 5.500	A 6.457	2F 5.000	B 6.142	BA 2.250
J 1.496	K 1.654	P 7.000	ES 1.575	depth 0.187
S 0.187	N-W 2.250	U 0.875	R 0.765	AB 6.811
D 3.500	G 0.429	O 7.000	H 0.344	C 13.752
AA NPT 3/4"	d1 A 4	d2 A 4	T 0.000	Flange FC-149
AJ 5.875	AK 4.500	BD 6.500	BF UNC 3/8"x16	BB 0.156
BC 0.125	AH 2.125			