



No.:

Date: 26-DEC-2012

Customer :

TECHNICAL PROPOSAL

Three-phase induction motor - Squirrel cage rotor

Product line : Three-Phase : Explosion Proof - NEMA Premium

Catalog Number : 00336XT3E182T

List Price : \$1,192

Notes:

Performed by:

Checked:



No.:

Date: 26-DEC-2012

## DATA SHEET

### Three-phase induction motor - Squirrel cage rotor

Customer :  
Product line : Three-Phase : Explosion Proof - NEMA Premium

Frame : 182T  
Output : 3 HP  
Frequency : 60 Hz  
Poles : 2  
Full load speed : 3515  
Slip : 2.36 %  
Voltage : 208-230/460 V  
Rated current : 8.40-7.60/3.80 A  
Locked rotor current : 66.9/33.4 A  
Locked rotor current (I<sub>L</sub>/I<sub>n</sub>) : 8.8  
No-load current : 3.20/1.60 A  
Full load torque : 4.42 lb.ft  
Locked rotor torque : 250 %  
Breakdown torque : 400 %  
Design : B  
Insulation class : F  
Temperature rise : 80 K  
Locked rotor time : 30 s (hot)  
Service factor : 1.15  
Duty cycle : S1  
Ambient temperature : -20°C - +40°C  
Altitude : 1000  
Degree of Protection : IP54  
Approximate weight : 90 lb  
Moment of inertia : 0.14713 sq.ft.lb  
Noise level : 69 dB(A)

	D.E.	N.D.E.	Load	Power factor	Efficiency (%)
Bearings	6307 ZZ	6206 ZZ	100%	0.84	86.5
Regreasing interval	---	---	75%	0.79	85.5
Grease amount	---	---	50%	0.69	82.5

Notes:

Performed by

Checked



No.:

Date: 26-DEC-2012

### PERFORMANCE CURVES RELATED TO RATED OUTPUT

Three-phase induction motor - Squirrel cage rotor

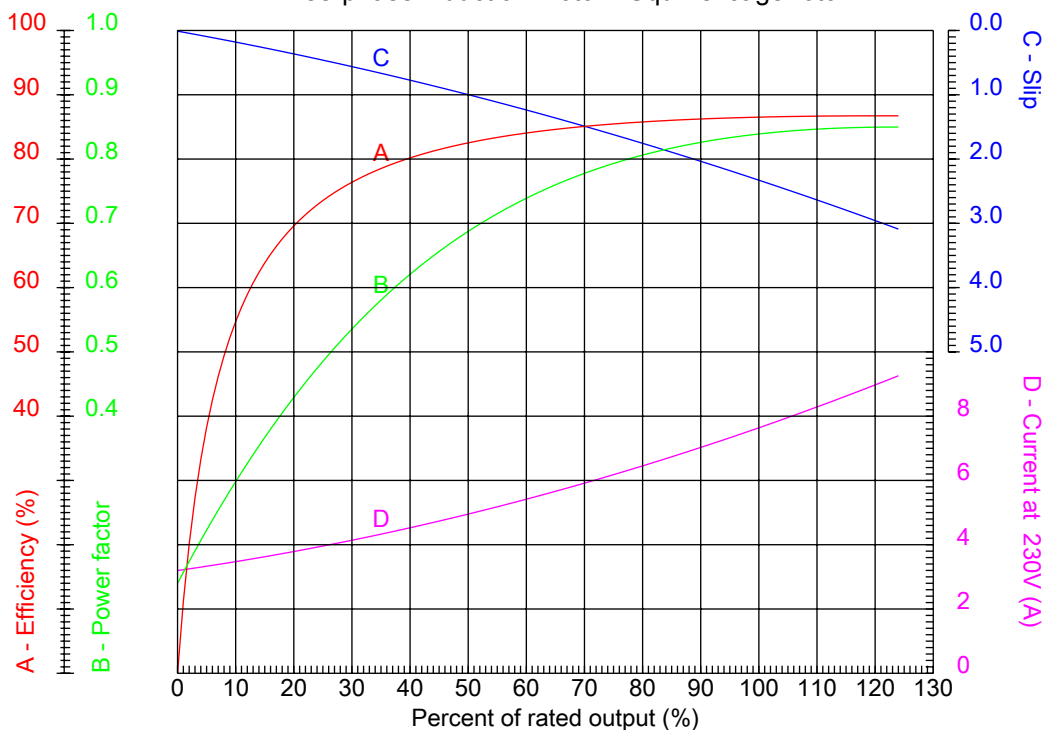

Customer :  
Product line : Three-Phase : Explosion Proof - NEMA Premium

Frame	: 182T	Locked rotor current (I <sub>L</sub> /I <sub>n</sub> )	: 8.8
Output	: 3 HP	Duty cycle	: S1
Frequency	: 60 Hz	Service factor	: 1.15
Full load speed	: 3515	Design	: B
Voltage	: 208-230/460 V	Locked rotor torque	: 250 %
Rated current	: 8.40-7.60/3.80 A	Breakdown torque	: 400 %
Insulation class	: F		

Notes:

Performed by

Checked



No.:

Date: 26-DEC-2012

### CHARACTERISTIC CURVES RELATED TO SPEED

Three-phase induction motor - Squirrel cage rotor

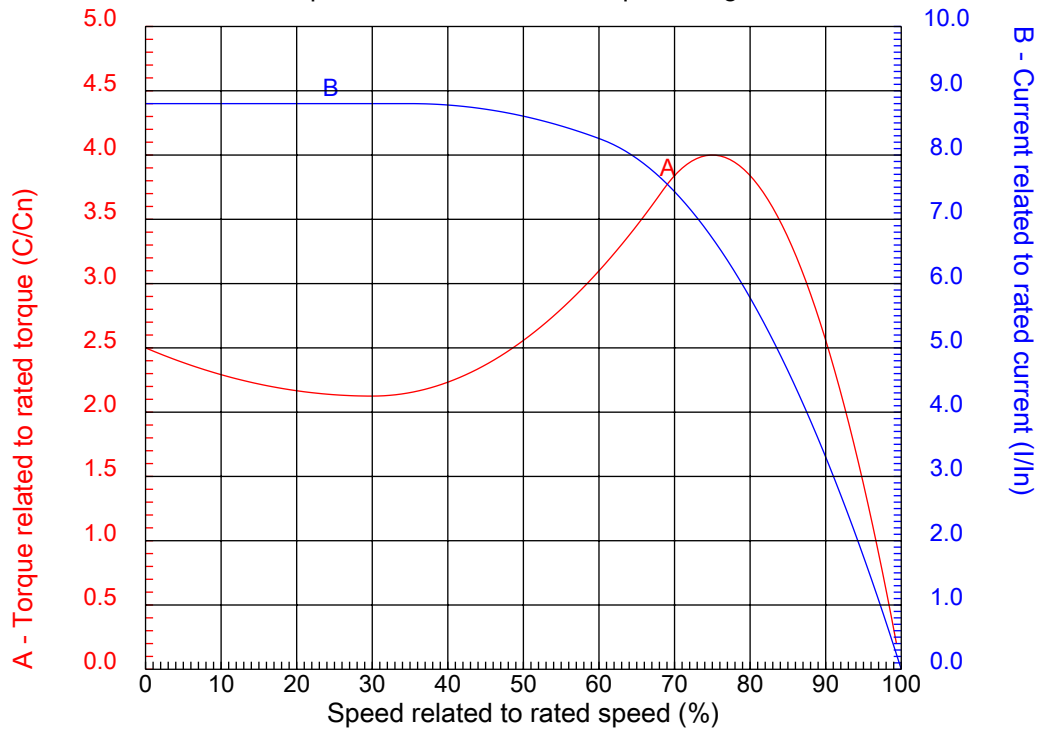

Customer :  
Product line : Three-Phase : Explosion Proof - NEMA Premium

Frame	: 182T	Locked rotor current (I <sub>l</sub> /I <sub>n</sub> )	: 8.8
Output	: 3 HP	Duty cycle	: S1
Frequency	: 60 Hz	Service factor	: 1.15
Full load speed	: 3515	Design	: B
Voltage	: 208-230/460 V	Locked rotor torque	: 250 %
Rated current	: 8.40-7.60/3.80 A	Breakdown torque	: 400 %
Insulation class	: F		

Notes:

Performed by

Checked

1 2 3 4 5 6 7 8

A

B

C

D

E

F

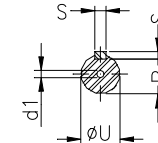
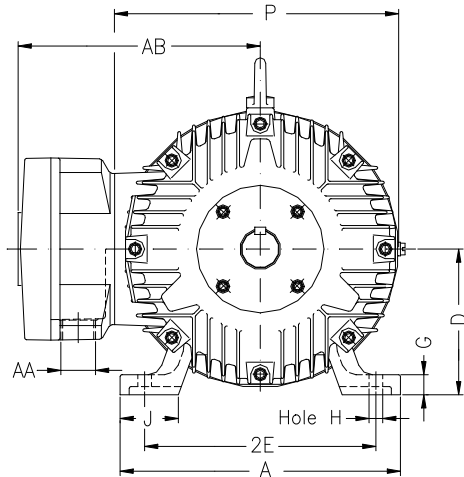

Notes:

Performed by:

Checked:

Customer:

Three-Phase : Explosion Proof - NEMA Premium

Three-phase induction motor  
Frame 182T - IP54

26-DEC-2012



2E 7.500	A 8.661	2F 4.500	B 5.945	BA 2.750
J 1.890	K 1.969	P 8.909	ES 1.969	depth 0.250
S 0.250	N-W 2.750	U 1.125	R 0.984	AB 8.240
D 4.500	G 0.787	O 9.421	HD 11.193	H 0.406
C 14.862	AA NPT 3/4"	d1 A 4	d2 A 4	T 1.772
Flange FD-254	AJ 10.000	AK 9.000	BD 11.000	BF 0.562
BB 0.203				