



No.:

Date: 27-DEC-2012

Customer :

TECHNICAL PROPOSAL

Three-phase induction motor - Squirrel cage rotor

Product line : Three-Phase : Explosion Proof - NEMA Premium

Catalog Number : 00509XT3E254T

List Price : \$3,953

Notes:

Performed by:

Checked:



No.:

Date: 27-DEC-2012

DATA SHEET

Three-phase induction motor - Squirrel cage rotor

Customer :
Product line : Three-Phase : Explosion Proof - NEMA Premium

Frame : 254T
Output : 5 HP
Frequency : 60 Hz
Poles : 8
Full load speed : 880
Slip : 2.22 %
Voltage : 208-230/460 V
Rated current : 17.5-15.9/7.93 A
Locked rotor current : 84.0/42.0 A
Locked rotor current (I_L/I_n) : 5.3
No-load current : 11.0/5.50 A
Full load torque : 29.4 lb.ft
Locked rotor torque : 210 %
Breakdown torque : 270 %
Design : B
Insulation class : F
Temperature rise : 80 K
Locked rotor time : 21 s (hot)
Service factor : 1.15
Duty cycle : S1
Ambient temperature : -20°C - +40°C
Altitude : 1000
Degree of Protection : IP54
Approximate weight : 313 lb
Moment of inertia : 3.4086 sq.ft.lb
Noise level : 54 dB(A)

	D.E.	N.D.E.	Load	Power factor	Efficiency (%)
Bearings	6309 C3	6209 C3	100%	0.67	87.5
Regreasing interval	20000 h	20000 h	75%	0.58	86.5
Grease amount	13 g	9 g	50%	0.46	84.0

Notes:

Performed by

Checked



No.:

Date: 27-DEC-2012

PERFORMANCE CURVES RELATED TO RATED OUTPUT

Three-phase induction motor - Squirrel cage rotor

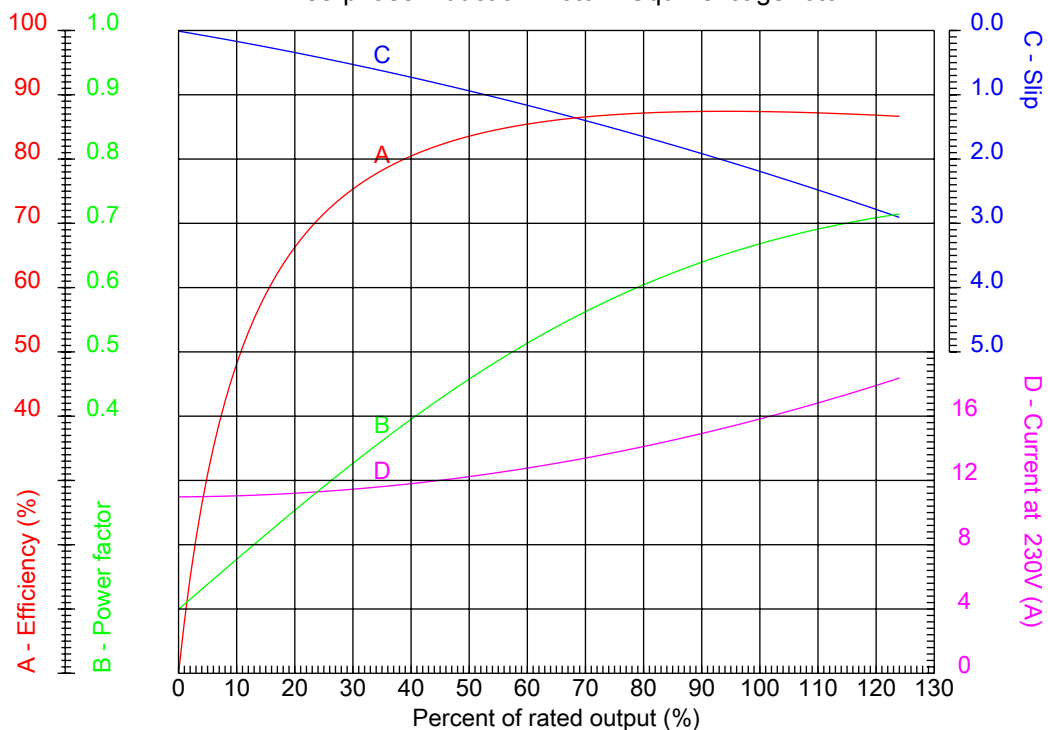

Customer :
Product line : Three-Phase : Explosion Proof - NEMA Premium

Frame	: 254T	Locked rotor current (I _l /I _n)	: 5.3
Output	: 5 HP	Duty cycle	: S1
Frequency	: 60 Hz	Service factor	: 1.15
Full load speed	: 880	Design	: B
Voltage	: 208-230/460 V	Locked rotor torque	: 210 %
Rated current	: 17.5-15.9/7.93 A	Breakdown torque	: 270 %
Insulation class	: F		

Notes:

Performed by

Checked



No.:

Date: 27-DEC-2012

CHARACTERISTIC CURVES RELATED TO SPEED

Three-phase induction motor - Squirrel cage rotor

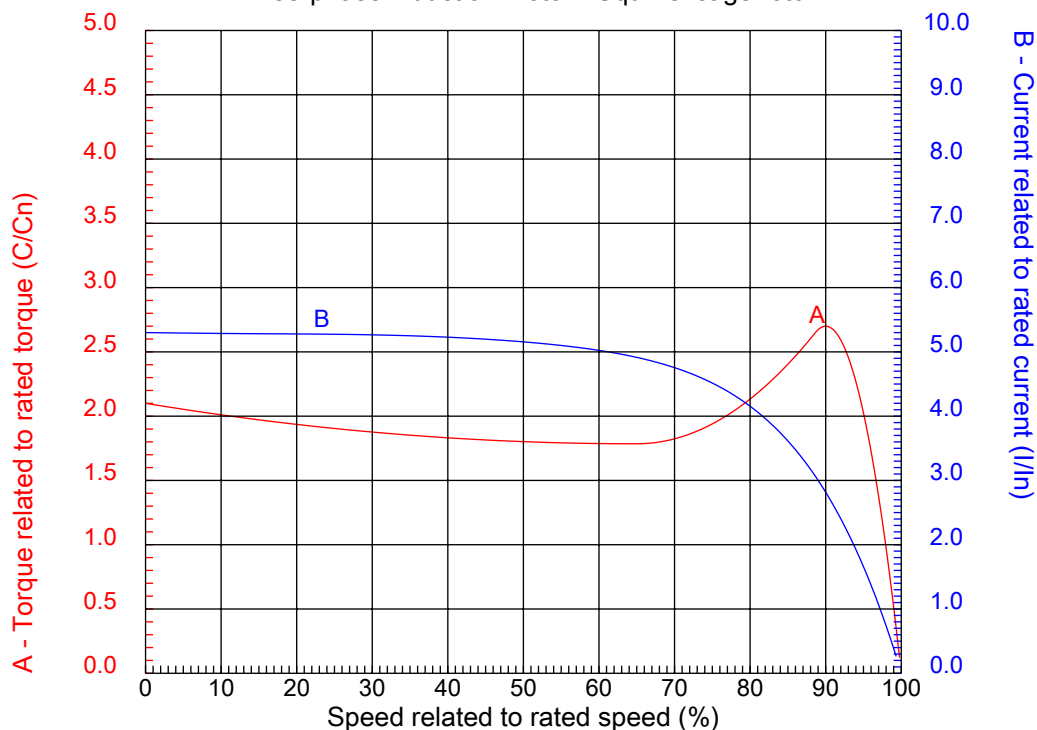

Customer :
Product line : Three-Phase : Explosion Proof - NEMA Premium

Frame	: 254T	Locked rotor current (I _l /I _n)	: 5.3
Output	: 5 HP	Duty cycle	: S1
Frequency	: 60 Hz	Service factor	: 1.15
Full load speed	: 880	Design	: B
Voltage	: 208-230/460 V	Locked rotor torque	: 210 %
Rated current	: 17.5-15.9/7.93 A	Breakdown torque	: 270 %
Insulation class	: F		

Notes:

Performed by

Checked

1 2 3 4 5 6 7 8

A

B

C

D

E

F

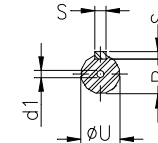
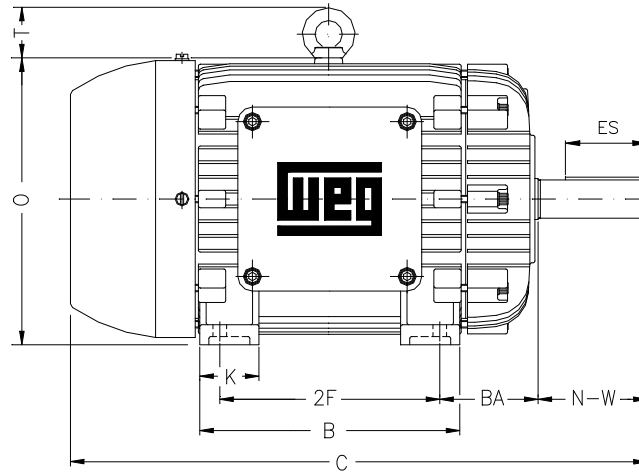
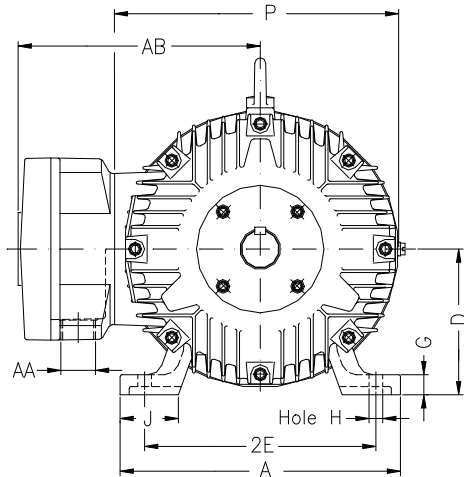

Notes:

Performed by:

Checked:

Customer:

Three-Phase : Explosion Proof - NEMA Premium

Three-phase induction motor
Frame 254T - IP54

27-DEC-2012



2E 10.000	A 12.126	2F 8.252	B 10.000	BA 4.250
J 2.520	K 2.559	P 12.224	ES 2.756	depth 0.375
S 0.375	N-W 4.000	U 1.625	R 1.406	AB 11.063
D 6.250	G 0.817	O 12.352	HD 14.439	H 0.531
C 23.175	AA NPT 1 1/2"	d1 A 4	d2 A 4	T 2.087
Flange FD-317	AJ 12.500	AK 11.000	BD 14.000	BF 0.828
BB 0.203				