



No.:

Date: 28-DEC-2012

Customer :

TECHNICAL PROPOSAL

Three-phase induction motor - Squirrel cage rotor

Product line : Saw Arbor Motors : Single and Double Shaft End

Catalog Number : 00718ES3ESA90LR

List Price : \$1,855

Notes:

Performed by:

Checked:



No.:

Date: 28-DEC-2012

DATA SHEET

Three-phase induction motor - Squirrel cage rotor

Customer :
Product line : Saw Arbor Motors : Single and Double Shaft End

Frame : 90L
Output : 7.5 HP
Frequency : 60 Hz
Poles : 4
Full load speed : 1730
Slip : 3.89 %
Voltage : 208-230/460 V
Rated current : 22.4-20.3/10.1 A
Locked rotor current : 166/83.1 A
Locked rotor current (I_L/I_n) : 8.2
No-load current : 10.0/5.02 A
Full load torque : 22.5 lb.ft
Locked rotor torque : 370 %
Breakdown torque : 400 %
Design : N
Insulation class : F
Temperature rise : 80 K
Locked rotor time : 7 s (hot)
Service factor : 1.15
Duty cycle : S6 50%
Ambient temperature : -20°C - +40°C
Altitude : 1000
Degree of Protection : IP54
Approximate weight : 165 lb
Moment of inertia : 0.33246 sq.ft.lb
Noise level : 51 dB(A)

	D.E.	N.D.E.	Load	Power factor	Efficiency (%)
Bearings	6308 ZZ	6208 ZZ	100%	0.80	85.3
Regreasing interval	---	---	75%	0.74	85.0
Grease amount	---	---	50%	0.60	83.5

Notes:

Performed by

Checked



No.:

Date: 28-DEC-2012

PERFORMANCE CURVES RELATED TO RATED OUTPUT Three-phase induction motor - Squirrel cage rotor

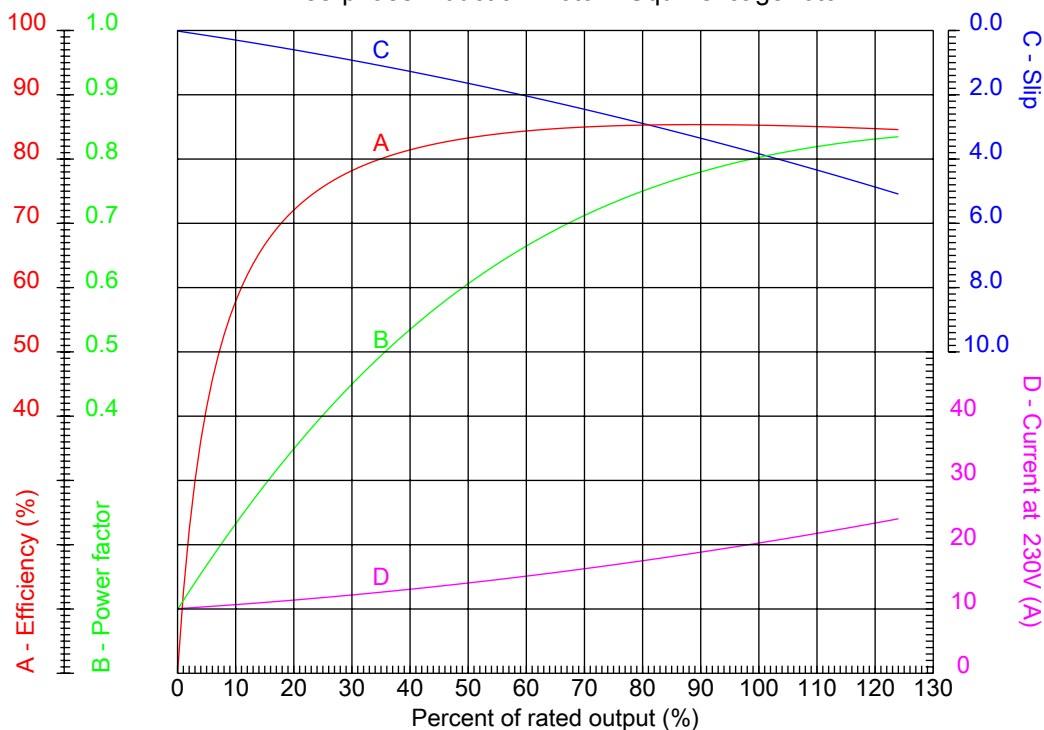

Customer :
Product line : Saw Arbor Motors : Single and Double Shaft End

Frame	: 90L	Locked rotor current (I _l /I _n)	: 8.2
Output	: 7.5 HP	Duty cycle	: S6 50%
Frequency	: 60 Hz	Service factor	: 1.15
Full load speed	: 1730	Design	: N
Voltage	: 208-230/460 V	Locked rotor torque	: 370 %
Rated current	: 22.4-20.3/10.1 A	Breakdown torque	: 400 %
Insulation class	: F		

Notes:

Performed by

Checked



No.:

Date: 28-DEC-2012

CHARACTERISTIC CURVES RELATED TO SPEED

Three-phase induction motor - Squirrel cage rotor

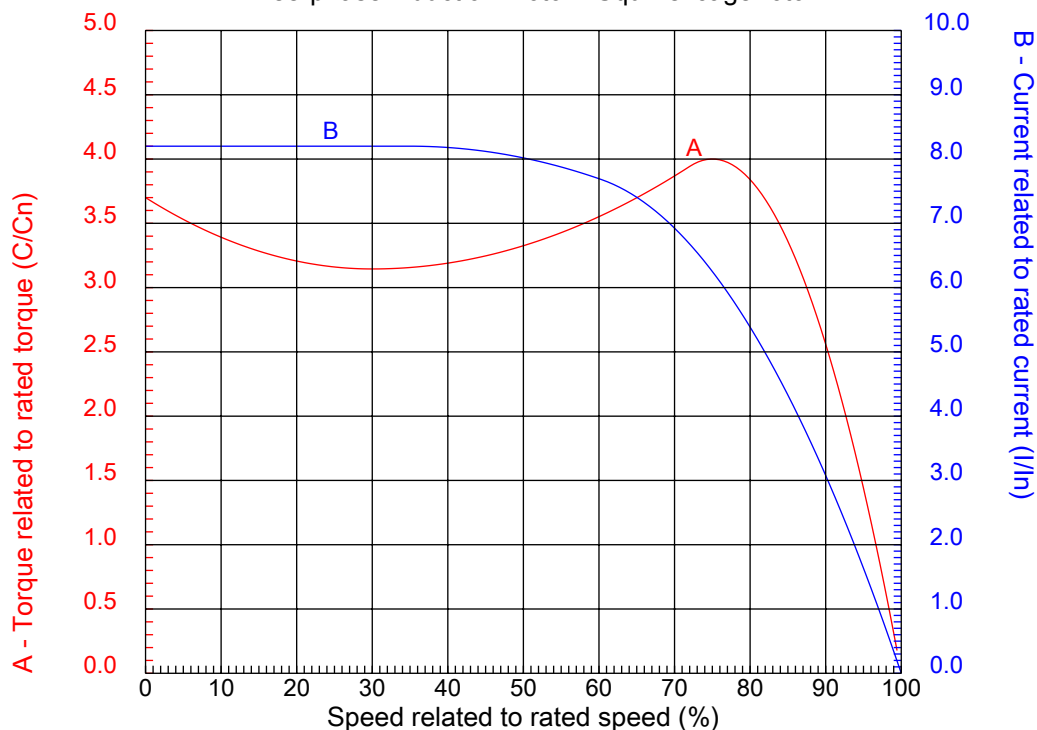

Customer :
Product line : Saw Arbor Motors : Single and Double Shaft End

Frame	: 90L	Locked rotor current (I _l /I _n)	: 8.2
Output	: 7.5 HP	Duty cycle	: S6 50%
Frequency	: 60 Hz	Service factor	: 1.15
Full load speed	: 1730	Design	: N
Voltage	: 208-230/460 V	Locked rotor torque	: 370 %
Rated current	: 22.4-20.3/10.1 A	Breakdown torque	: 400 %
Insulation class	: F		

Notes:

Performed by

Checked

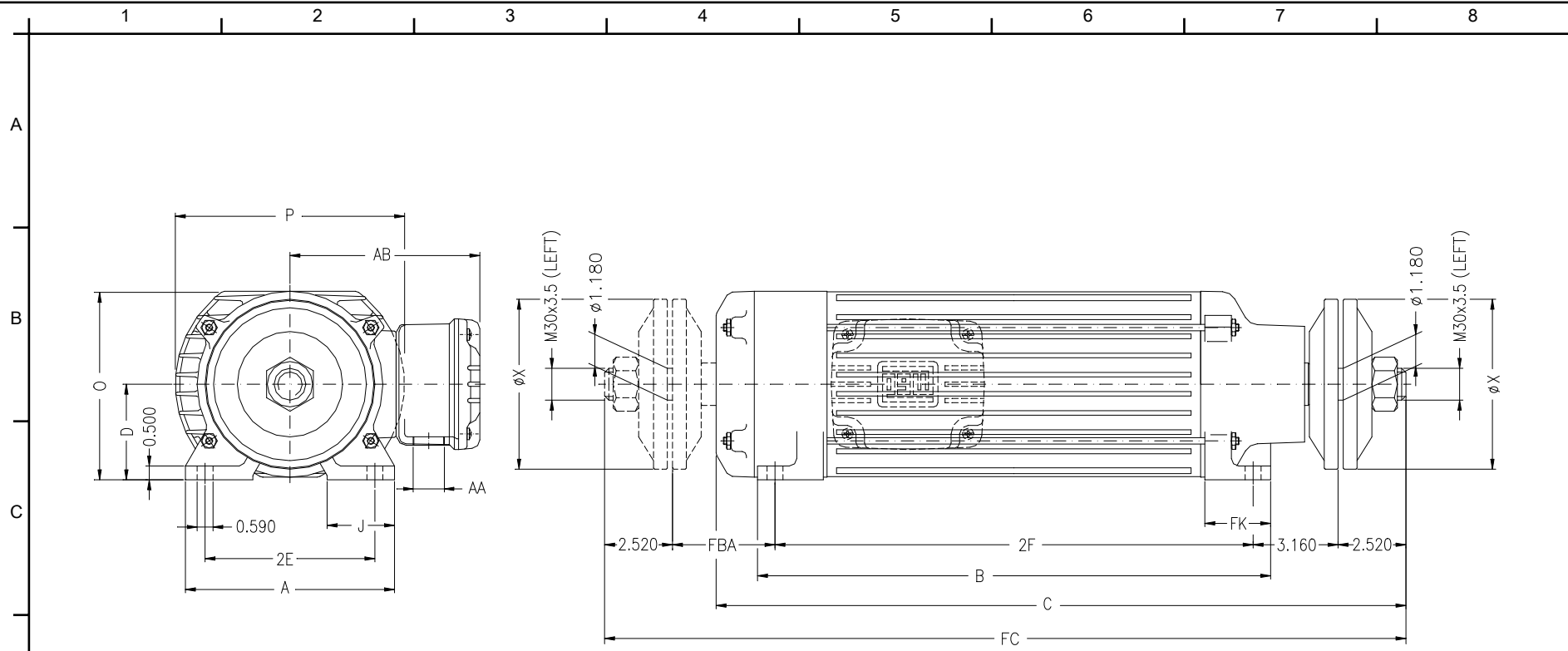

D

E

F

2E	2F	A	B	FK
160	510	197	543	62
FBA	C	FC	D	J
43	672.5	758.0	90	63
O	P	AB	AA	
177	208	179	NPT 1"	

Notes:		
Performed by:		
Checked:		
Customer:		
Saw Arbor Motors : Single and Double Shaft End		
Three-phase induction motor Frame 90L - IP54	28-DEC-2012	