



No.:

Date: 27-DEC-2012

Customer :

TECHNICAL PROPOSAL

Three-phase induction motor - Squirrel cage rotor

Product line : Three-Phase : Explosion Proof - NEMA Premium

Catalog Number : 01018XT3ER215TC

List Price : \$2,220

Notes:

Performed by:

Checked:



No.:

Date: 27-DEC-2012

## DATA SHEET

### Three-phase induction motor - Squirrel cage rotor

Customer :  
Product line : Three-Phase : Explosion Proof - NEMA Premium

Frame : 215T  
Output : 10 HP  
Frequency : 60 Hz  
Poles : 4  
Full load speed : 1765  
Slip : 1.94 %  
Voltage : 208-230/460 V  
Rated current : 28.1-25.4/12.7 A  
Locked rotor current : 191/95.3 A  
Locked rotor current (I<sub>L</sub>/I<sub>n</sub>) : 7.5  
No-load current : 12.6/6.30 A  
Full load torque : 29.4 lb.ft  
Locked rotor torque : 250 %  
Breakdown torque : 300 %  
Design : B  
Insulation class : F  
Temperature rise : 80 K  
Locked rotor time : 15 s (hot)  
Service factor : 1.15  
Duty cycle : S1  
Ambient temperature : -20°C - +40°C  
Altitude : 1000  
Degree of Protection : IP54  
Approximate weight : 207 lb  
Moment of inertia : 1.3362 sq.ft.lb  
Noise level : 58 dB(A)

	D.E.	N.D.E.	Load	Power factor	Efficiency (%)
Bearings	6308 ZZ	6207 ZZ	100%	0.81	91.7
Regreasing interval	---	---	75%	0.75	91.0
Grease amount	---	---	50%	0.62	90.2

Notes:

Performed by

Checked



No.:

Date: 27-DEC-2012

### PERFORMANCE CURVES RELATED TO RATED OUTPUT

Three-phase induction motor - Squirrel cage rotor

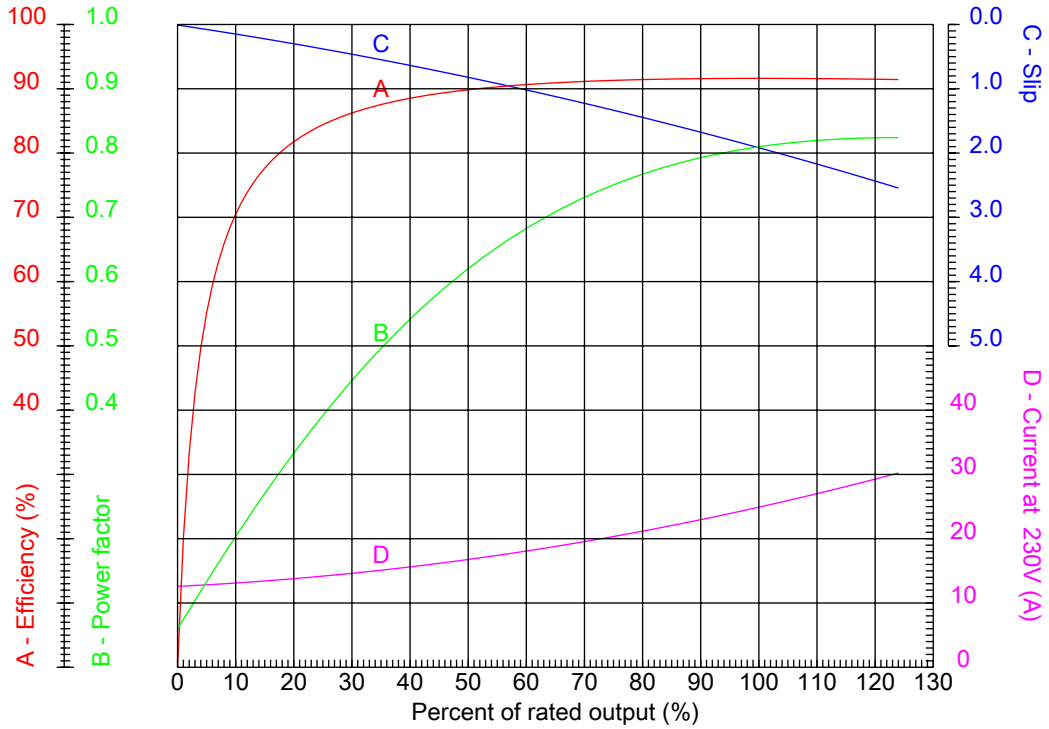

Customer :  
Product line : Three-Phase : Explosion Proof - NEMA Premium

Frame	: 215T	Locked rotor current (I <sub>l</sub> /I <sub>n</sub> )	: 7.5
Output	: 10 HP	Duty cycle	: S1
Frequency	: 60 Hz	Service factor	: 1.15
Full load speed	: 1765	Design	: B
Voltage	: 208-230/460 V	Locked rotor torque	: 250 %
Rated current	: 28.1-25.4/12.7 A	Breakdown torque	: 300 %
Insulation class	: F		

Notes:

Performed by

Checked



No.:

Date: 27-DEC-2012

### CHARACTERISTIC CURVES RELATED TO SPEED Three-phase induction motor - Squirrel cage rotor

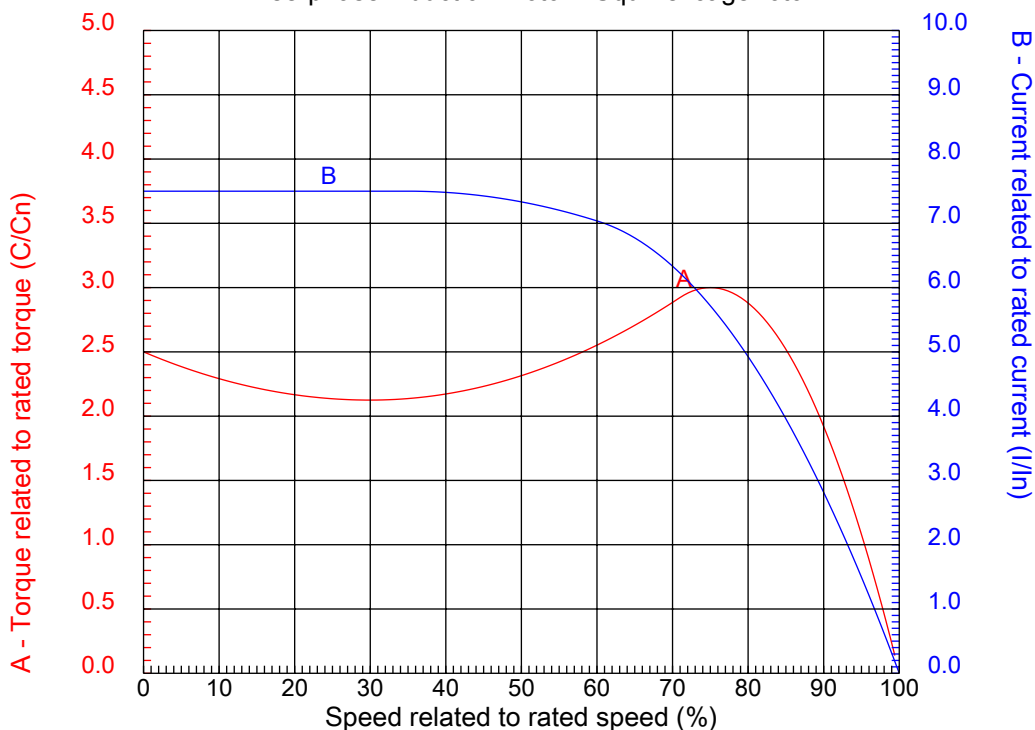

Customer :  
Product line : Three-Phase : Explosion Proof - NEMA Premium

Frame	: 215T	Locked rotor current (I <sub>l</sub> /I <sub>n</sub> )	: 7.5
Output	: 10 HP	Duty cycle	: S1
Frequency	: 60 Hz	Service factor	: 1.15
Full load speed	: 1765	Design	: B
Voltage	: 208-230/460 V	Locked rotor torque	: 250 %
Rated current	: 28.1-25.4/12.7 A	Breakdown torque	: 300 %
Insulation class	: F		

Notes:

Performed by

Checked

1 2 3 4 5 6 7 8

A

B

C

D

E

F

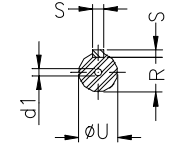
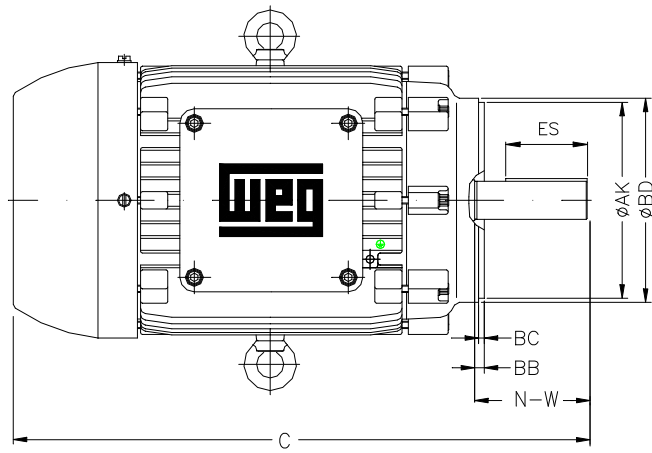
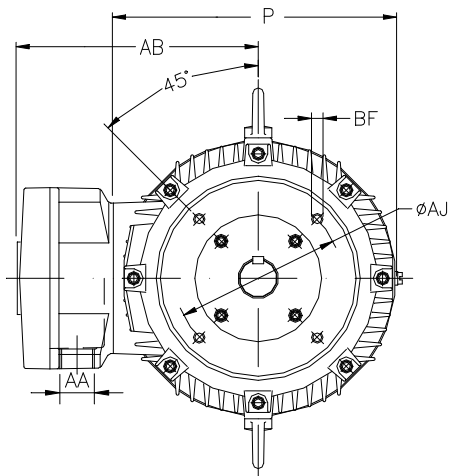

Notes:

Performed by:

Checked:

Customer:

Three-Phase : Explosion Proof - NEMA Premium

Three-phase induction motor  
Frame 215T - IP54

27-DEC-2012



P	ES	S	depth	N-W
10.709	2.480	0.313	0.313	3.375
U	R	AB	C	AA
1.375	1.203	9.252	19.450	NPT 1"
d1	d2	Flange	AJ	AK
A 4	A 4	FC-184	7.250	8.500
BD	BF	BB	BC	AH
8.875	UNC 1/2"x13	0.250	0.250	3.125