



No.:

Date: 28-DEC-2012

Customer :

TECHNICAL PROPOSAL

Three-phase induction motor - Squirrel cage rotor

Product line : Saw Arbor Motors : Single and Double Shaft End

Catalog Number : 01036ES3ESA90LL

List Price : \$1,953

Notes:

Performed by:

Checked:



No.:

Date: 28-DEC-2012

DATA SHEET

Three-phase induction motor - Squirrel cage rotor

Customer :
Product line : Saw Arbor Motors : Single and Double Shaft End

Frame : 90L
Output : 10 HP
Frequency : 60 Hz
Poles : 2
Full load speed : 3480
Slip : 3.33 %
Voltage : 208-230/460 V
Rated current : 27.2-24.6/12.3 A
Locked rotor current : 209/104 A
Locked rotor current (I_L/I_n) : 8.5
No-load current : 8.99/4.50 A
Full load torque : 14.9 lb.ft
Locked rotor torque : 400 %
Breakdown torque : 420 %
Design : N
Insulation class : F
Temperature rise : 80 K
Locked rotor time : 7 s (hot)
Service factor : 1.15
Duty cycle : S6 50%
Ambient temperature : -20°C - +40°C
Altitude : 1000
Degree of Protection : IP54
Approximate weight : 166 lb
Moment of inertia : 0.33222 sq.ft.lb
Noise level : 68 dB(A)

	D.E.	N.D.E.	Load	Power factor	Efficiency (%)
Bearings	6308 ZZ	6208 ZZ	100%	0.90	85.0
Regreasing interval	---	---	75%	0.86	84.5
Grease amount	---	---	50%	0.77	82.0

Notes:

Performed by

Checked



No.:

Date: 28-DEC-2012

PERFORMANCE CURVES RELATED TO RATED OUTPUT
Three-phase induction motor - Squirrel cage rotor

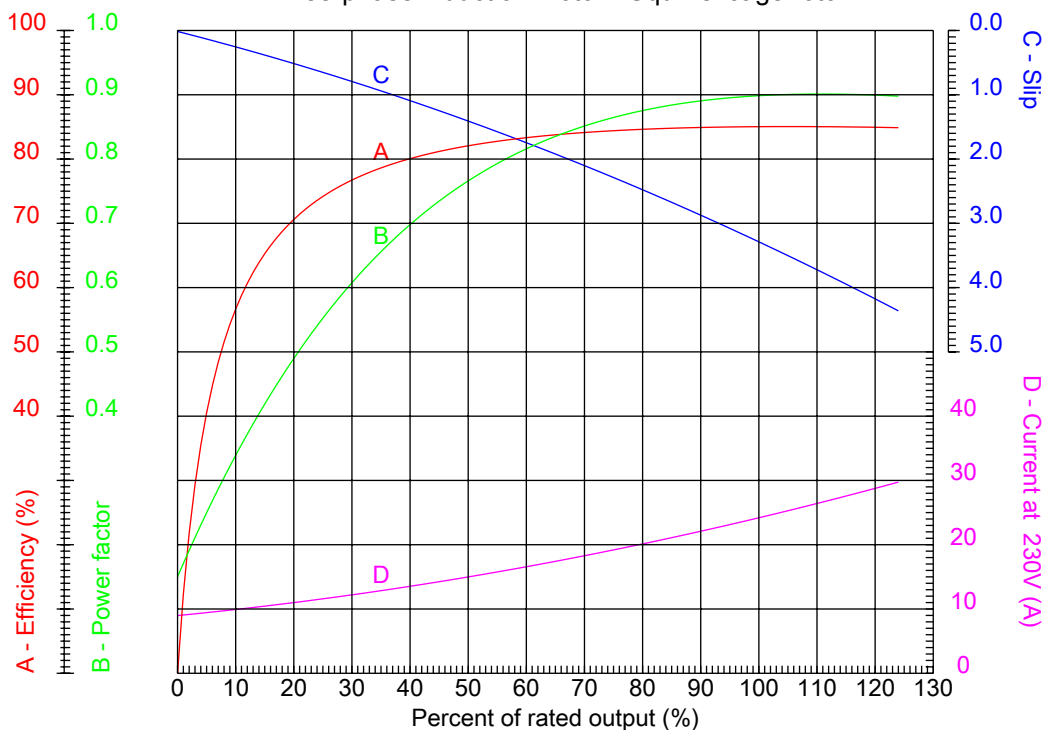

Customer :
Product line : Saw Arbor Motors : Single and Double Shaft End

Frame	: 90L	Locked rotor current (I _l /I _n)	: 8.5
Output	: 10 HP	Duty cycle	: S6 50%
Frequency	: 60 Hz	Service factor	: 1.15
Full load speed	: 3480	Design	: N
Voltage	: 208-230/460 V	Locked rotor torque	: 400 %
Rated current	: 27.2-24.6/12.3 A	Breakdown torque	: 420 %
Insulation class	: F		

Notes:

Performed by

Checked



No.:

Date: 28-DEC-2012

CHARACTERISTIC CURVES RELATED TO SPEED

Three-phase induction motor - Squirrel cage rotor

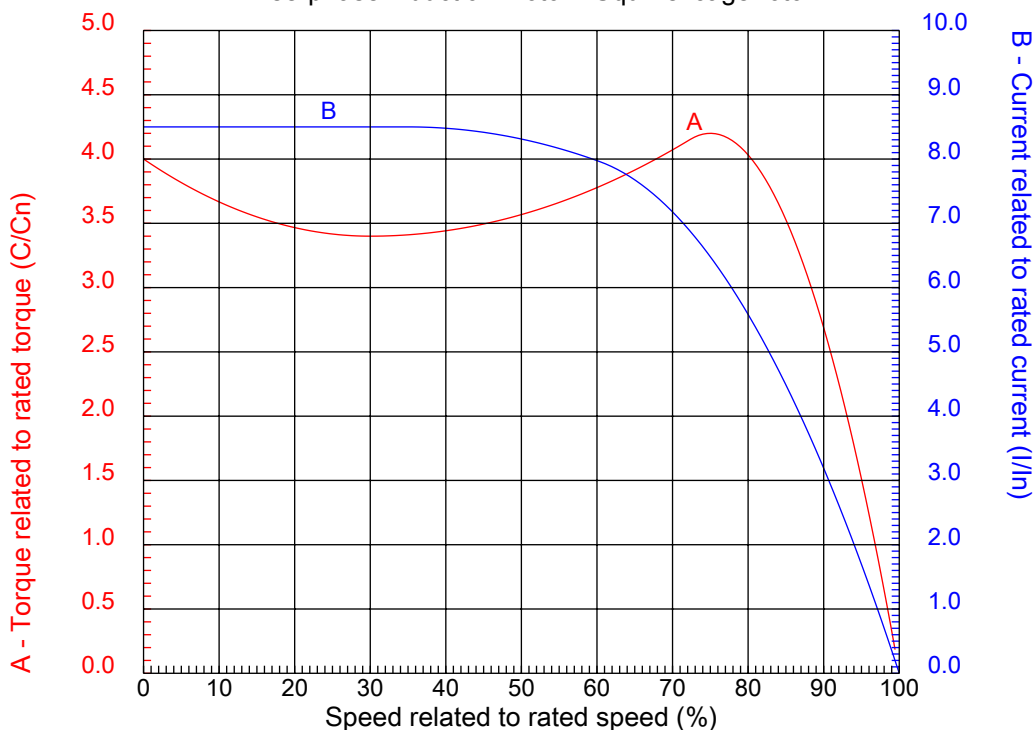

Customer :
Product line : Saw Arbor Motors : Single and Double Shaft End

Frame	: 90L	Locked rotor current (I _l /I _n)	: 8.5
Output	: 10 HP	Duty cycle	: S6 50%
Frequency	: 60 Hz	Service factor	: 1.15
Full load speed	: 3480	Design	: N
Voltage	: 208-230/460 V	Locked rotor torque	: 400 %
Rated current	: 27.2-24.6/12.3 A	Breakdown torque	: 420 %
Insulation class	: F		

Notes:

Performed by

Checked

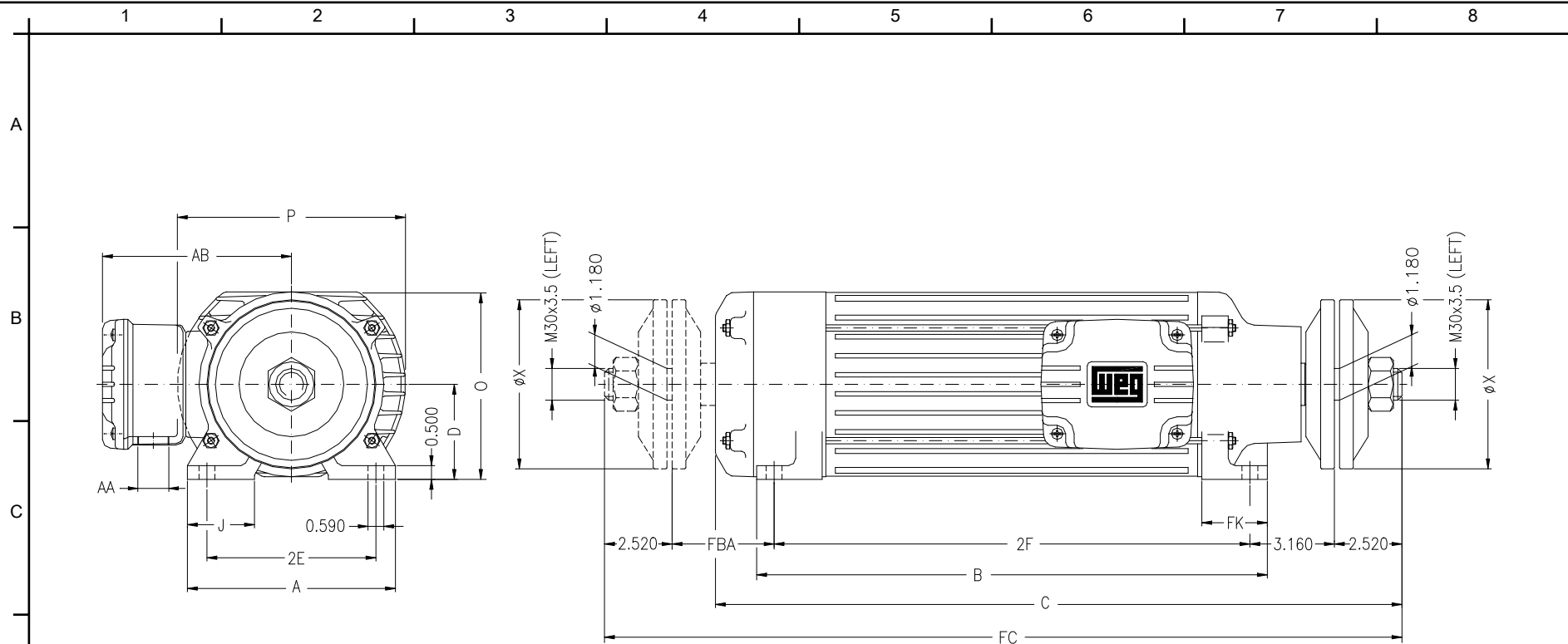

F	2E 160	2F 510	A 197	B 543	FK 62
	FBA 43	C 672.5	FC 758.0	D 90	J 63
	O 177	P 208	AB 179	AA NPT 1"	

Notes:		
Performed by:		
Checked:		
Customer:		
Saw Arbor Motors : Single and Double Shaft End		
Three-phase induction motor Frame 90L - IP54	28-DEC-2012	