



No.:

Date: 27-DEC-2012

Customer :

TECHNICAL PROPOSAL

Three-phase induction motor - Squirrel cage rotor

Product line : Three-Phase : Explosion Proof - NEMA Premium

Catalog Number : 02018XT3ER256TC

List Price : \$3,391

Notes:

Performed by:

Checked:



No.:

Date: 27-DEC-2012

DATA SHEET

Three-phase induction motor - Squirrel cage rotor

Customer :
Product line : Three-Phase : Explosion Proof - NEMA Premium

Frame : 256T
Output : 20 HP
Frequency : 60 Hz
Poles : 4
Full load speed : 1770
Slip : 1.67 %
Voltage : 208-230/460 V
Rated current : 55.3-50.0/25.0 A
Locked rotor current : 375/188 A
Locked rotor current (I_L/I_n) : 7.5
No-load current : 23.6/11.8 A
Full load torque : 58.5 lb.ft
Locked rotor torque : 300 %
Breakdown torque : 300 %
Design : B
Insulation class : F
Temperature rise : 80 K
Locked rotor time : 20 s (hot)
Service factor : 1.15
Duty cycle : S1
Ambient temperature : -20°C - +40°C
Altitude : 1000
Degree of Protection : IP54
Approximate weight : 364 lb
Moment of inertia : 2.8889 sq.ft.lb
Noise level : 69 dB(A)

	D.E.	N.D.E.	Load	Power factor	Efficiency (%)
Bearings	6309 C3	6209 Z-C3	100%	0.81	93.0
Regreasing interval	20000 h	20000 h	75%	0.75	92.4
Grease amount	13 g	9 g	50%	0.63	91.7

Notes:

Performed by

Checked



No.:

Date: 27-DEC-2012

PERFORMANCE CURVES RELATED TO RATED OUTPUT

Three-phase induction motor - Squirrel cage rotor

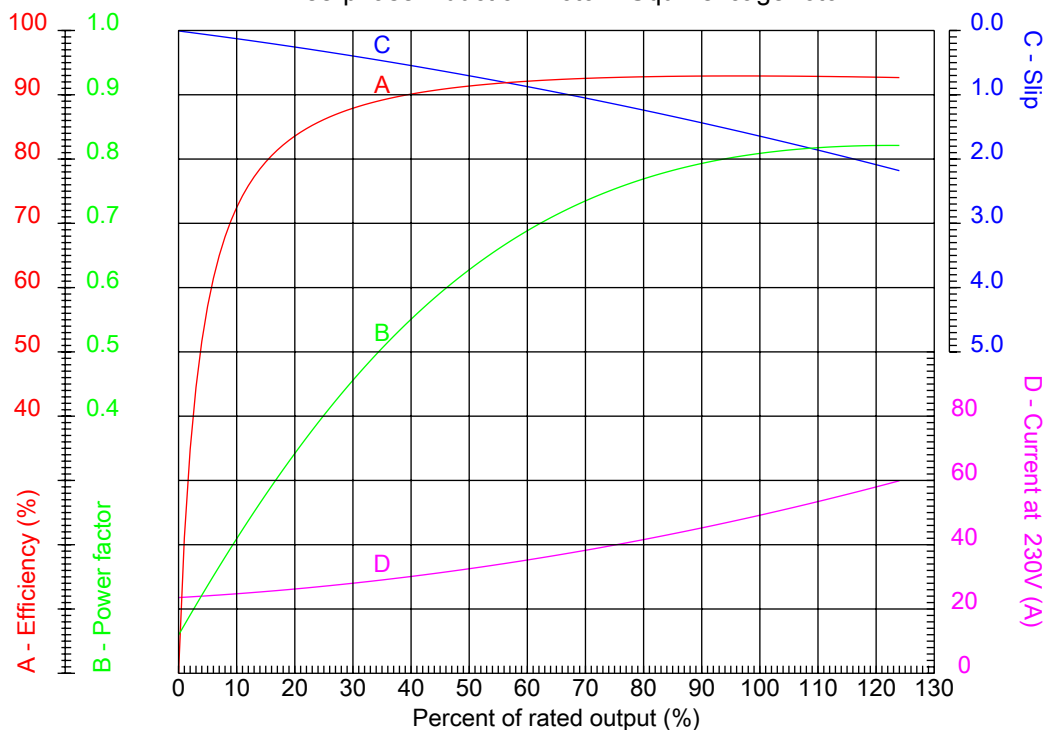

Customer :
Product line : Three-Phase : Explosion Proof - NEMA Premium

Frame	: 256T	Locked rotor current (I _l /I _n)	: 7.5
Output	: 20 HP	Duty cycle	: S1
Frequency	: 60 Hz	Service factor	: 1.15
Full load speed	: 1770	Design	: B
Voltage	: 208-230/460 V	Locked rotor torque	: 300 %
Rated current	: 55.3-50.0/25.0 A	Breakdown torque	: 300 %
Insulation class	: F		

Notes:

Performed by

Checked



No.:

Date: 27-DEC-2012

CHARACTERISTIC CURVES RELATED TO SPEED Three-phase induction motor - Squirrel cage rotor

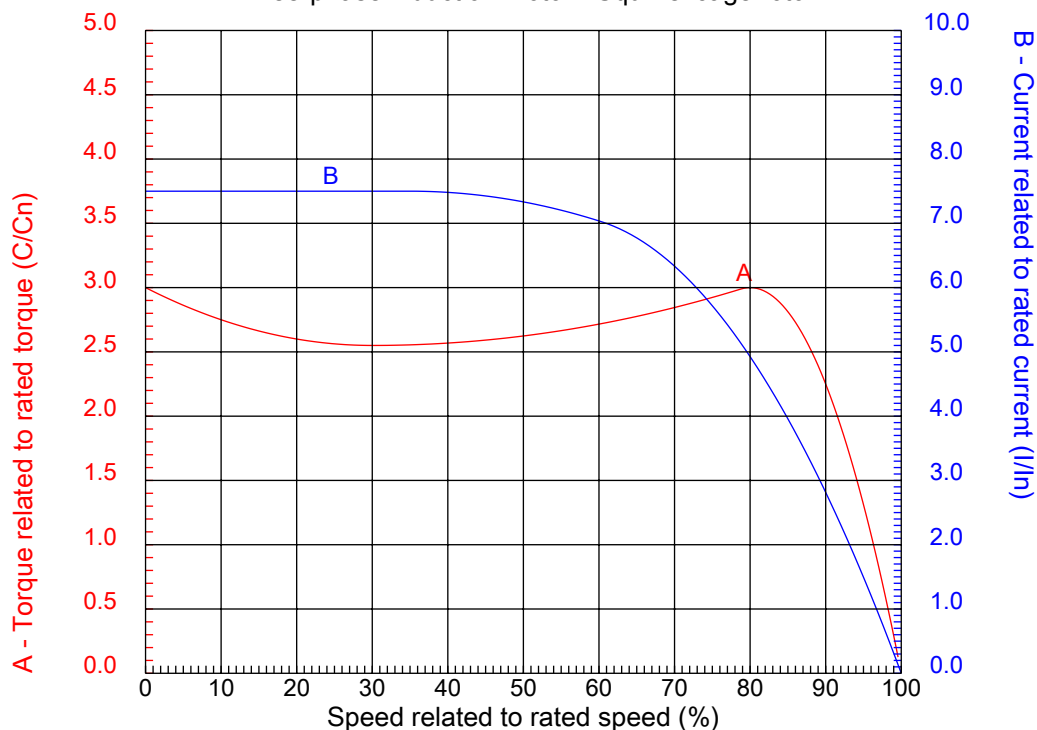

Customer :
Product line : Three-Phase : Explosion Proof - NEMA Premium

Frame	: 256T	Locked rotor current (I _l /I _{ln})	: 7.5
Output	: 20 HP	Duty cycle	: S1
Frequency	: 60 Hz	Service factor	: 1.15
Full load speed	: 1770	Design	: B
Voltage	: 208-230/460 V	Locked rotor torque	: 300 %
Rated current	: 55.3-50.0/25.0 A	Breakdown torque	: 300 %
Insulation class	: F		

Notes:

Performed by

Checked

1 2 3 4 5 6 7 8

A

B

C

D

E

F

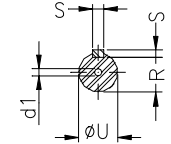
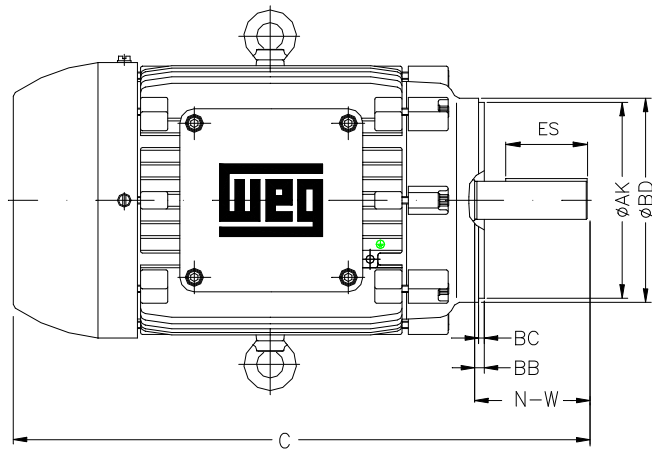
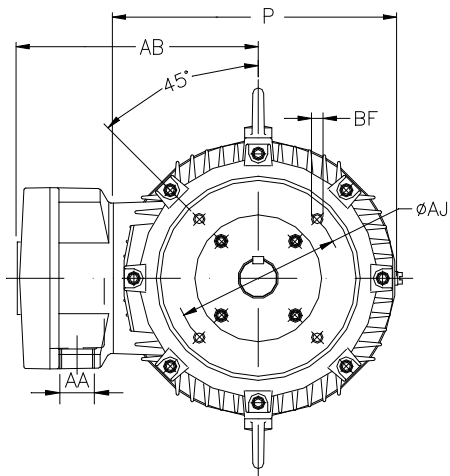

Notes:

Performed by:

Checked:

Customer:

Three-Phase : Explosion Proof - NEMA Premium

Three-phase induction motor
Frame 256T - IP54

27-DEC-2012



P 12.224	ES 2.756	S 0.375	depth 0.375	N-W 4.000
U 1.625	R 1.406	AB 11.063	C 24.923	AA NPT 1 1/2"
d1 A 4	d2 A 4	Flange FC-184	AJ 7.250	AK 8.500
BD 8.875	BF UNC 1/2"x13	BB 0.250	BC 0.250	AH 3.750