



No.:

Date: 27-DEC-2012

Customer :

TECHNICAL PROPOSAL

Three-phase induction motor - Squirrel cage rotor

Product line : Close Coupled Pump: Three-Phase - W22 "JM" Type - TEFC - NEMA Premium

Catalog Number : 05036ET3E326JM-W22

List Price : \$6,622

Notes:

Performed by:

Checked:



No.:

Date: 27-DEC-2012

## DATA SHEET

### Three-phase induction motor - Squirrel cage rotor

Customer :  
 Product line : Close Coupled Pump: Three-Phase - W22 "JM" Type - TEFC - NEMA Premium

Frame : 326JM  
 Output : 50 HP  
 Frequency : 60 Hz  
 Poles : 2  
 Full load speed : 3550  
 Slip : 1.39 %  
 Voltage : 208-230/460 V  
 Rated current : 124-112/56.1 A  
 Locked rotor current : 696/348 A  
 Locked rotor current (I<sub>L</sub>/I<sub>n</sub>) : 6.2  
 No-load current : 30.0/15.0 A  
 Full load torque : 73.0 lb.ft  
 Locked rotor torque : 220 %  
 Breakdown torque : 230 %  
 Design : B  
 Insulation class : F  
 Temperature rise : 80 K  
 Locked rotor time : 23 s (hot)  
 Service factor : 1.25  
 Duty cycle : S1  
 Ambient temperature : -20°C - +40°C  
 Altitude : 1000  
 Degree of Protection : IP55  
 Approximate weight : 584 lb  
 Moment of inertia : 5.7469 sq.ft.lb  
 Noise level : 78 dB(A)

	D.E.	N.D.E.	Load	Power factor	Efficiency (%)
Bearings	6312 C3	6212 C3	100%	0.89	93.0
Regreasing interval	12000 h	15000 h	75%	0.87	93.0
Grease amount	21 g	13 g	50%	0.83	93.0

Notes:

Performed by

Checked



No.:

Date: 27-DEC-2012

PERFORMANCE CURVES RELATED TO RATED OUTPUT

Three-phase induction motor - Squirrel cage rotor

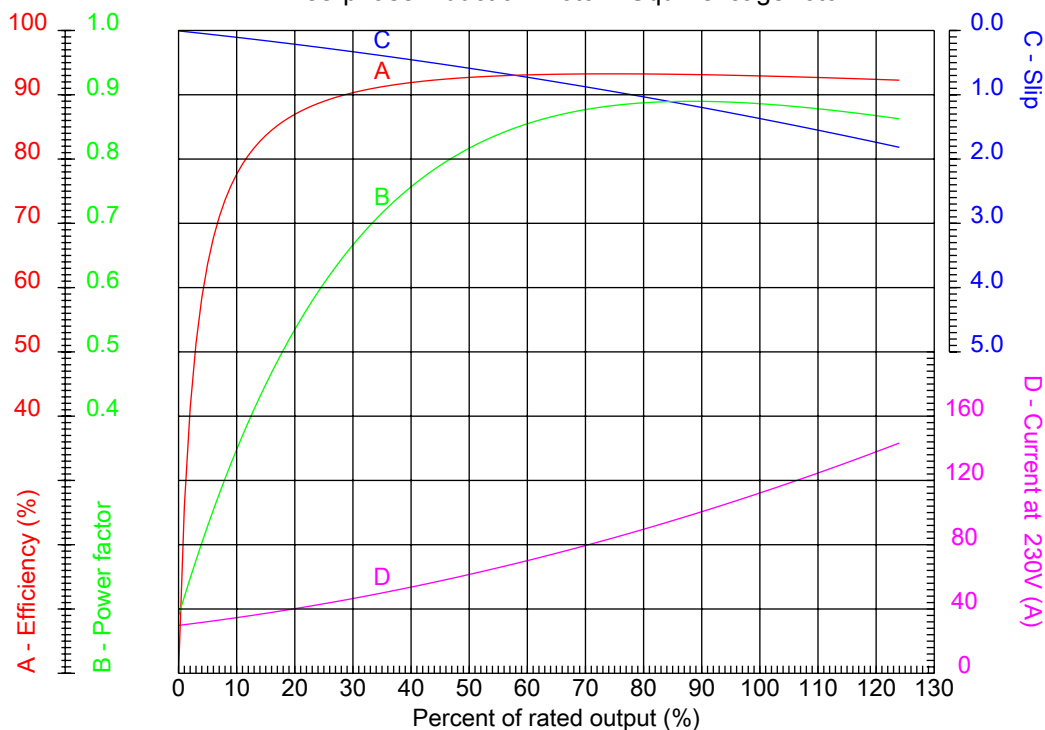

Customer :  
 Product line : Close Coupled Pump: Three-Phase - W22 "JM" Type - TEFC - NEMA Premium

Frame	: 326JM	Locked rotor current (I <sub>l</sub> /I <sub>n</sub> )	: 6.2
Output	: 50 HP	Duty cycle	: S1
Frequency	: 60 Hz	Service factor	: 1.25
Full load speed	: 3550	Design	: B
Voltage	: 208-230/460 V	Locked rotor torque	: 220 %
Rated current	: 124-112/56.1 A	Breakdown torque	: 230 %
Insulation class	: F		

Notes:

Performed by

Checked



No.:

Date: 27-DEC-2012

### CHARACTERISTIC CURVES RELATED TO SPEED

Three-phase induction motor - Squirrel cage rotor

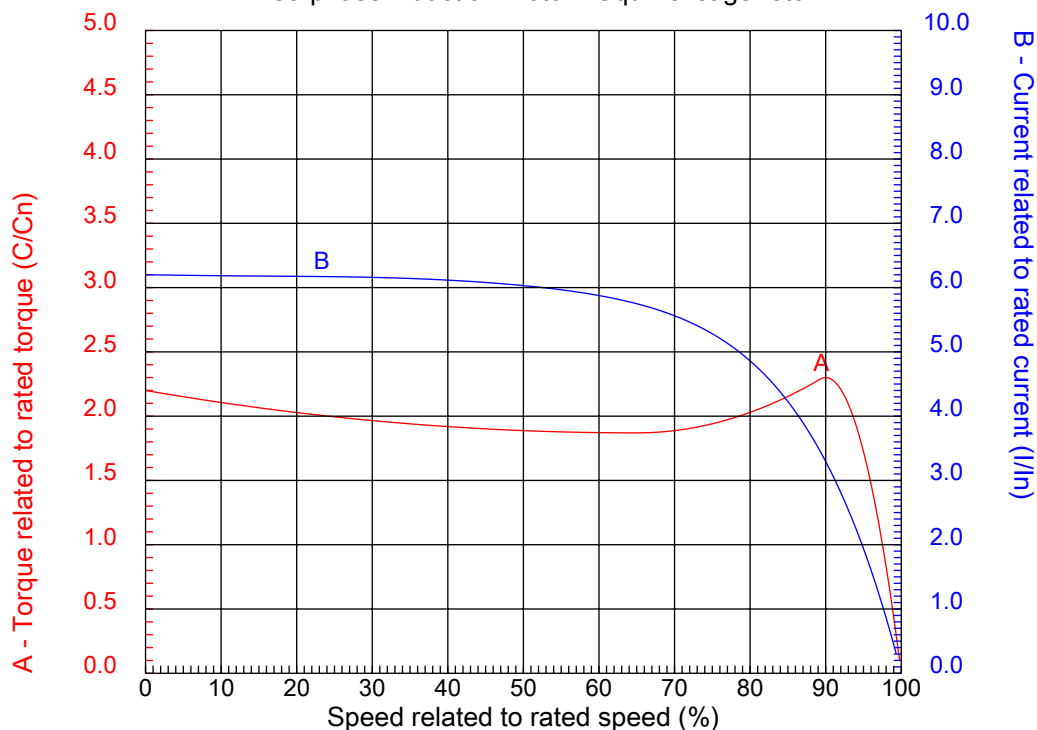

Customer :  
Product line : Close Coupled Pump: Three-Phase - W22 "JM" Type - TEFC - NEMA Premium

Frame	: 326JM	Locked rotor current (I <sub>l</sub> /I <sub>n</sub> )	: 6.2
Output	: 50 HP	Duty cycle	: S1
Frequency	: 60 Hz	Service factor	: 1.25
Full load speed	: 3550	Design	: B
Voltage	: 208-230/460 V	Locked rotor torque	: 220 %
Rated current	: 124-112/56.1 A	Breakdown torque	: 230 %
Insulation class	: F		

Notes:

Performed by

Checked

1 2 3 4 5 6 7 8

A

B

C

D

E

F

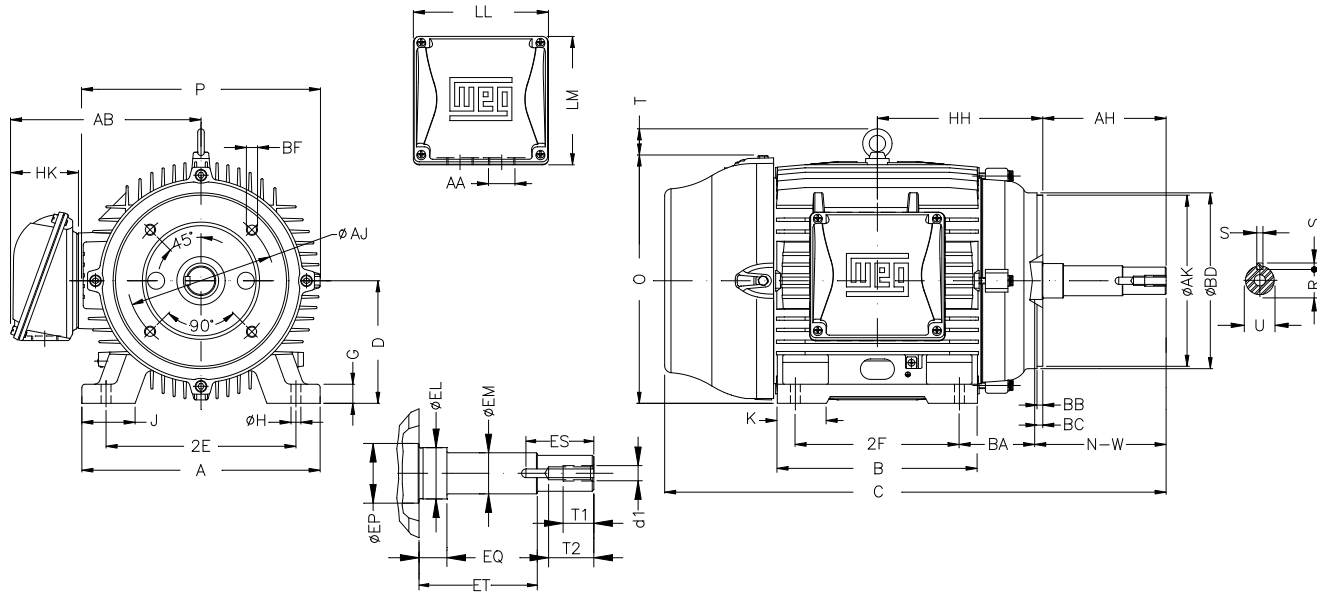

Notes:

Performed by:

Checked:

Customer:

Close Coupled Pump: Three-Phase - W22 "JM" Type - TEFC - NEMA Premium

Three-phase induction motor  
Frame 326JM - IP55

27-DEC-2012



2E 12.500	J 3.189	A 15.157	P 15.827	AB 12.480
2F 12.000	K 3.189	B 14.567	BA 5.250	D 8.000
G 1.300	O 15.953	T 2.441	HD 18.394	H 0.657
AA NPT 2"	ER 5.250	EQ 0.630	ET 3.006	U 1.249
EM 1.375	EL 1.750	EP 2.360	ES 2.480	t1 0.984
t2 1.496	C 29.645	Flange FC-279	AJ 11.000	AK 12.500
BD 13.593	BF UNC 5/8"x11	BB 0.248	BC ---	AH 5.250