



No.:

Date: 27-DEC-2012

Customer :

TECHNICAL PROPOSAL

Three-phase induction motor - Squirrel cage rotor

Product line : Three-Phase : Explosion Proof - NEMA Premium

Catalog Number : 07509XT3E444T

List Price : \$29,094

Notes:

Performed by:

Checked:



No.:

Date: 27-DEC-2012

## DATA SHEET

### Three-phase induction motor - Squirrel cage rotor

Customer :  
Product line : Three-Phase : Explosion Proof - NEMA Premium

Frame : 444/5T  
Output : 75 HP  
Frequency : 60 Hz  
Poles : 8  
Full load speed : 890  
Slip : 1.11 %  
Voltage : 208-230/460 V  
Rated current : 204-184/92.2 A  
Locked rotor current : 1120/562 A  
Locked rotor current (I<sub>L</sub>/I<sub>n</sub>) : 6.1  
No-load current : 76.0/38.0 A  
Full load torque : 437 lb.ft  
Locked rotor torque : 170 %  
Breakdown torque : 210 %  
Design : B  
Insulation class : F  
Temperature rise : 80 K  
Locked rotor time : 18 s (hot)  
Service factor : 1.15  
Duty cycle : S1  
Ambient temperature : -20°C - +40°C  
Altitude : 1000  
Degree of Protection : IP54  
Approximate weight : 1912 lb  
Moment of inertia : 73.625 sq.ft.lb  
Noise level : 64 dB(A)

	D.E.	N.D.E.	Load	Power factor	Efficiency (%)
Bearings	6219 C3	6316 C3	100%	0.80	93.6
Regreasing interval	15247 h	15904 h	75%	0.76	94.1
Grease amount	27 g	34 g	50%	0.66	93.6

Notes:

Performed by

Checked



No.:

Date: 27-DEC-2012

### PERFORMANCE CURVES RELATED TO RATED OUTPUT Three-phase induction motor - Squirrel cage rotor

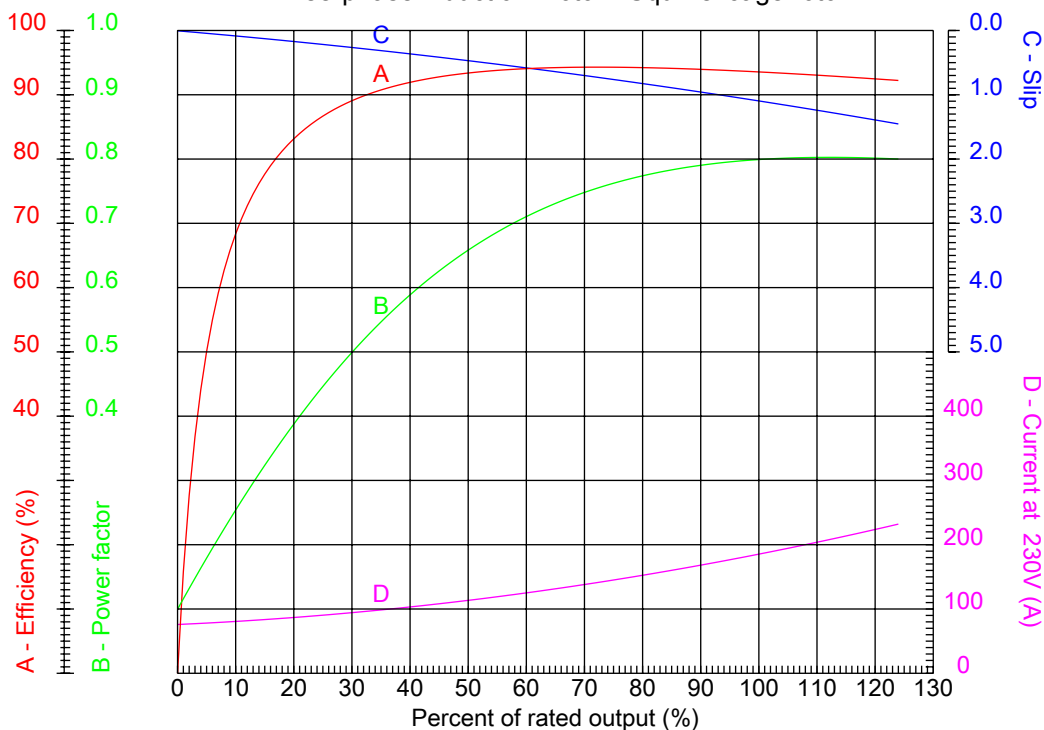

Customer :  
Product line : Three-Phase : Explosion Proof - NEMA Premium

Frame	: 444/5T	Locked rotor current (I <sub>L</sub> /I <sub>n</sub> )	: 6.1
Output	: 75 HP	Duty cycle	: S1
Frequency	: 60 Hz	Service factor	: 1.15
Full load speed	: 890	Design	: B
Voltage	: 208-230/460 V	Locked rotor torque	: 170 %
Rated current	: 204-184/92.2 A	Breakdown torque	: 210 %
Insulation class	: F		

Notes:

Performed by

Checked



No.:

Date: 27-DEC-2012

### CHARACTERISTIC CURVES RELATED TO SPEED

Three-phase induction motor - Squirrel cage rotor

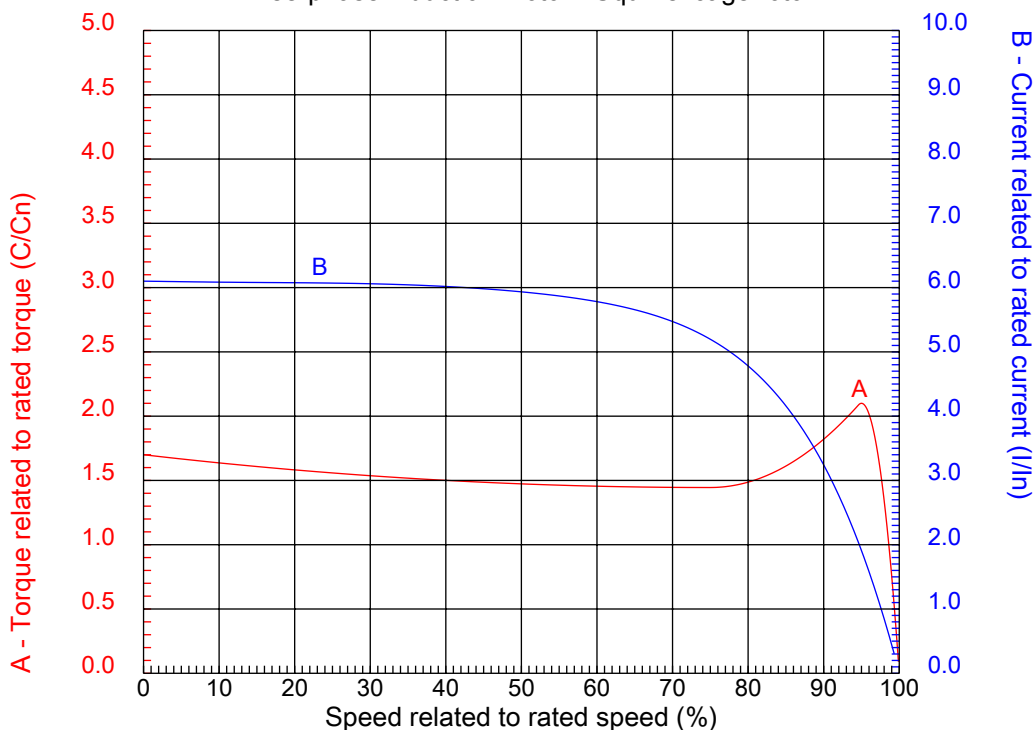

Customer :  
Product line : Three-Phase : Explosion Proof - NEMA Premium

Frame	: 444/5T	Locked rotor current (I <sub>l</sub> /I <sub>n</sub> )	: 6.1
Output	: 75 HP	Duty cycle	: S1
Frequency	: 60 Hz	Service factor	: 1.15
Full load speed	: 890	Design	: B
Voltage	: 208-230/460 V	Locked rotor torque	: 170 %
Rated current	: 204-184/92.2 A	Breakdown torque	: 210 %
Insulation class	: F		

Notes:

Performed by

Checked

1 2 3 4 5 6 7 8

A

B

C

D

E

F

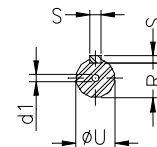
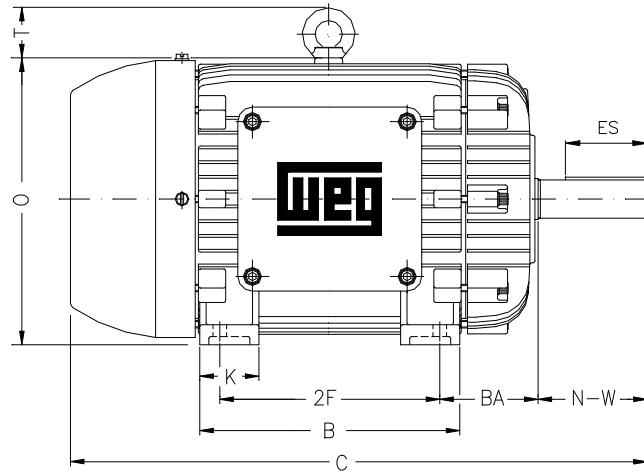
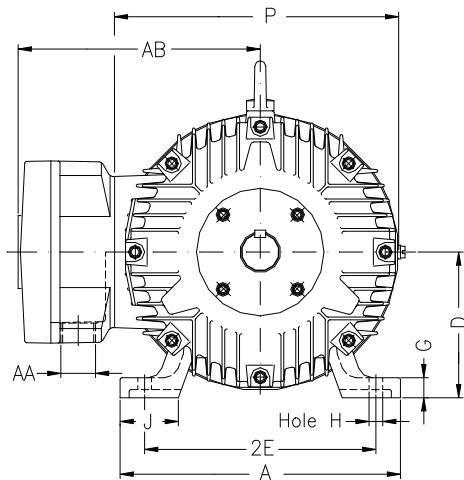

Notes:

2E 18.000	A 21.929	2F 14.500/16.500	B 20.079	BA 7.500
J 3.937	FBA 11.769/13.769	K 5.591	P 24.016	ES 7.087
depth 0.875	S 0.875	N-W 8.500	U 3.375	R 2.880
AB 21.732	D 11.000	G 1.630	O 23.622	HD 27.165
H 0.807	C 43.797	AA 2XNPT 3"	d1 DUNC 3/4"-10	d2 DUNC 3/4"-10
T 3.543	Flange FD-508	AJ 20.000	AK 18.000	BD 21.656
BF 0.828	BB 0.203			

Performed by:

Checked:

Customer:

Three-Phase : Explosion Proof - NEMA Premium

Three-phase induction motor  
Frame 444/5T - IP54

27-DEC-2012

