



No.:

Date: 27-DEC-2012

Customer :

TECHNICAL PROPOSAL

Three-phase induction motor - Squirrel cage rotor

Product line : Three-Phase : Explosion Proof - NEMA Premium

Catalog Number : 10009XT3G445T

List Price : \$31,191

Notes:

Performed by:

Checked:



No.:

Date: 27-DEC-2012

DATA SHEET

Three-phase induction motor - Squirrel cage rotor

Customer :
Product line : Three-Phase : Explosion Proof - NEMA Premium

Frame : 444/5T
Output : 100 HP
Frequency : 60 Hz
Poles : 8
Full load speed : 890
Slip : 1.11 %
Voltage : 460 V
Rated current : 125 A
Locked rotor current : 763 A
Locked rotor current (I_L/I_n) : 6.1
No-load current : 47.5 A
Full load torque : 582 lb.ft
Locked rotor torque : 170 %
Breakdown torque : 200 %
Design : B
Insulation class : F
Temperature rise : 80 K
Locked rotor time : 16 s (hot)
Service factor : 1.15
Duty cycle : S1
Ambient temperature : -20°C - +40°C
Altitude : 1000
Degree of Protection : IP54
Approximate weight : 2053 lb
Moment of inertia : 87.260 sq.ft.lb
Noise level : 64 dB(A)

	D.E.	N.D.E.	Load	Power factor	Efficiency (%)
Bearings	6219 C3	6316 C3	100%	0.80	94.1
Regreasing interval	15247 h	15904 h	75%	0.77	94.5
Grease amount	27 g	34 g	50%	0.68	94.1

Notes:

Performed by

Checked



No.:

Date: 27-DEC-2012

PERFORMANCE CURVES RELATED TO RATED OUTPUT

Three-phase induction motor - Squirrel cage rotor

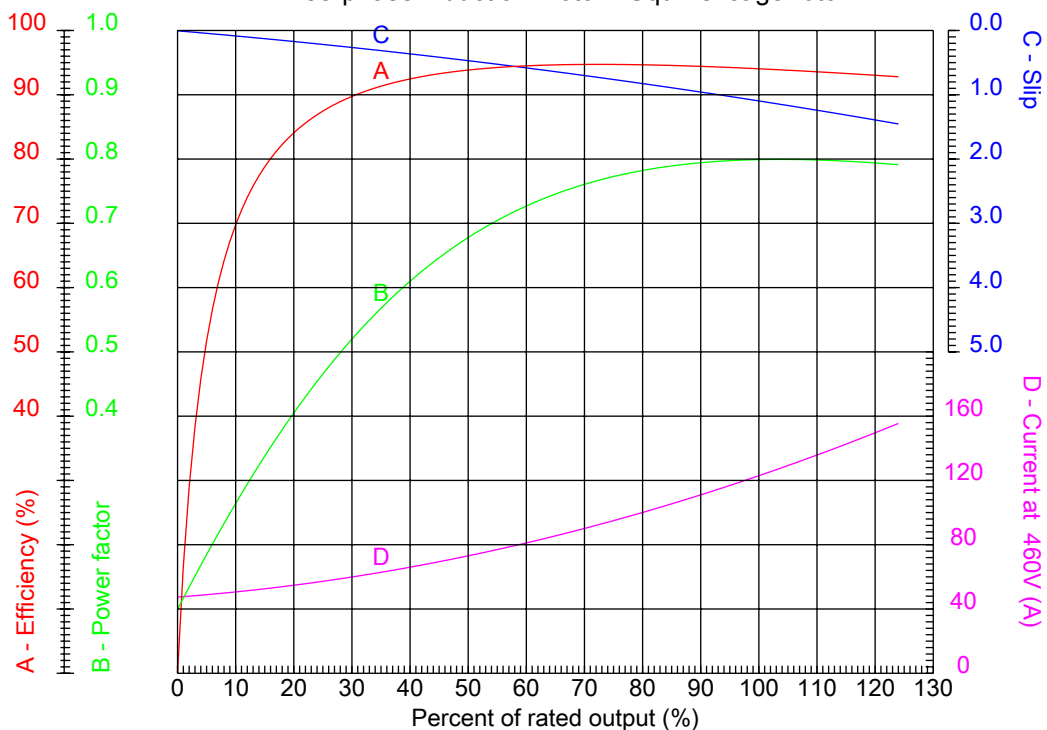

Customer :
Product line : Three-Phase : Explosion Proof - NEMA Premium

Frame : 444/5T	Locked rotor current (I _L /I _n) : 6.1
Output : 100 HP	Duty cycle : S1
Frequency : 60 Hz	Service factor : 1.15
Full load speed : 890	Design : B
Voltage : 460 V	Locked rotor torque : 170 %
Rated current : 125 A	Breakdown torque : 200 %
Insulation class : F	

Notes:

Performed by

Checked



No.:

Date: 27-DEC-2012

CHARACTERISTIC CURVES RELATED TO SPEED Three-phase induction motor - Squirrel cage rotor

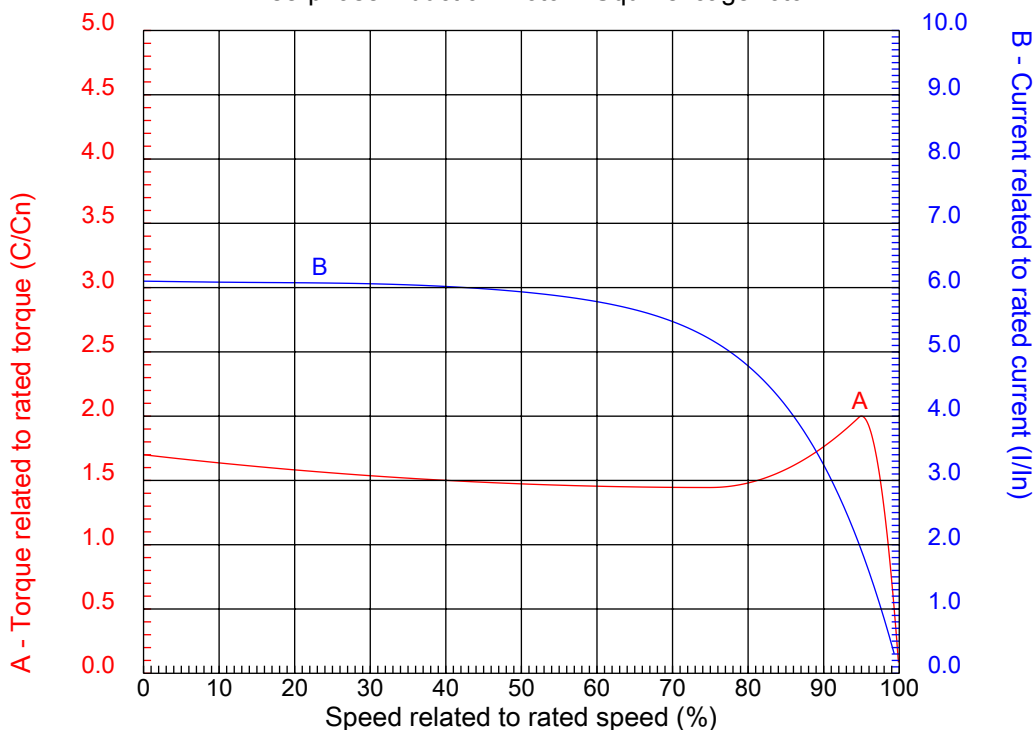

Customer :
Product line : Three-Phase : Explosion Proof - NEMA Premium

Frame	: 444/5T	Locked rotor current (I _l /I _n)	: 6.1
Output	: 100 HP	Duty cycle	: S1
Frequency	: 60 Hz	Service factor	: 1.15
Full load speed	: 890	Design	: B
Voltage	: 460 V	Locked rotor torque	: 170 %
Rated current	: 125 A	Breakdown torque	: 200 %
Insulation class	: F		

Notes:

Performed by

Checked

1 2 3 4 5 6 7 8

A

B

C

D

E

F

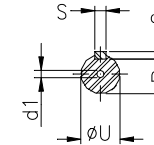
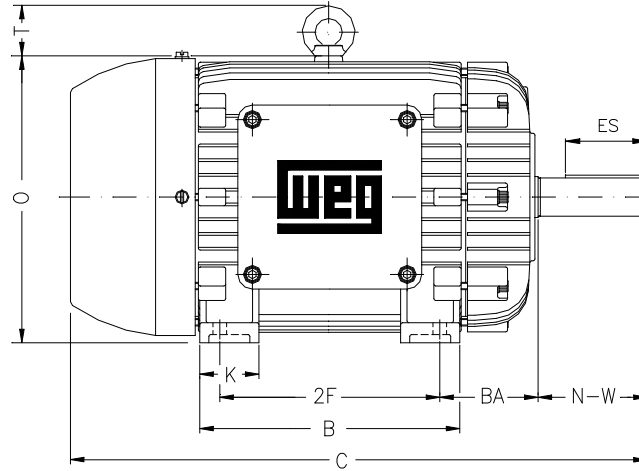
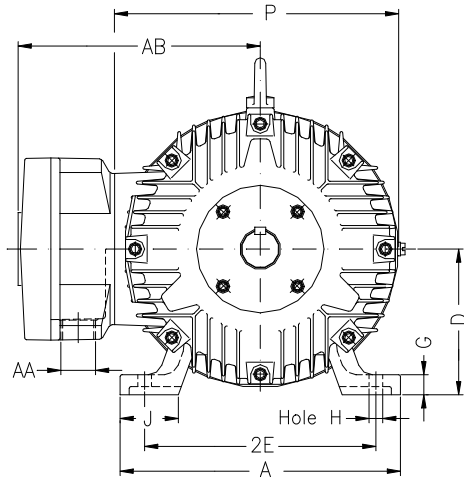

Notes:

Performed by:

Checked:

Customer:

Three-Phase : Explosion Proof - NEMA Premium

Three-phase induction motor
Frame 444/5T - IP54

27-DEC-2012



2E 18.000	A 21.929	2F 14.500/16.500	B 20.079	BA 7.500
J 3.937	FBA 11.769/13.769	K 5.591	P 24.016	ES 7.087
depth 0.875	S 0.875	N-W 8.500	U 3.375	R 2.880
AB 21.732	D 11.000	G 1.630	O 23.622	HD 27.165
H 0.807	C 43.797	AA 2XNPT 3"	d1 DUNC 3/4"-10	d2 DUNC 3/4"-10
T 3.543	Flange FD-508	AJ 20.000	AK 18.000	BD 21.656
BF 0.828	BB 0.203			