



No.:

Date: 28-DEC-2012

Customer :

TECHNICAL PROPOSAL

Three-phase induction motor - Squirrel cage rotor

Product line : Three-Phase : Explosion Proof - NEMA Premium

Catalog Number : 35018XT3G449T

List Price : \$53,222

Notes:

Performed by:

Checked:



No.:

Date: 28-DEC-2012

DATA SHEET

Three-phase induction motor - Squirrel cage rotor

Customer :
Product line : Three-Phase : Explosion Proof - NEMA Premium

Frame : 449T
Output : 350 HP
Frequency : 60 Hz
Poles : 4
Full load speed : 1780
Slip : 1.11 %
Voltage : 460 V
Rated current : 390 A
Locked rotor current : 3040 A
Locked rotor current (I_L/I_n) : 7.8
No-load current : 126 A
Full load torque : 1019 lb.ft
Locked rotor torque : 280 %
Breakdown torque : 290 %
Design : A
Insulation class : F
Temperature rise : 80 K
Locked rotor time : 14 s (hot)
Service factor : 1.15
Duty cycle : S1
Ambient temperature : -20°C - +40°C
Altitude : 1000
Degree of Protection : IP54
Approximate weight : 3418 lb
Moment of inertia : 118.14 sq.ft.lb
Noise level : 80 dB(A)

	D.E.	N.D.E.	Load	Power factor	Efficiency (%)
Bearings	6322 C3	6319 C3	100%	0.87	96.2
Regreasing interval	5138 h	7038 h	75%	0.84	95.8
Grease amount	60 g	45 g	50%	0.76	95.4

Notes:

Performed by

Checked



No.:

Date: 28-DEC-2012

PERFORMANCE CURVES RELATED TO RATED OUTPUT Three-phase induction motor - Squirrel cage rotor

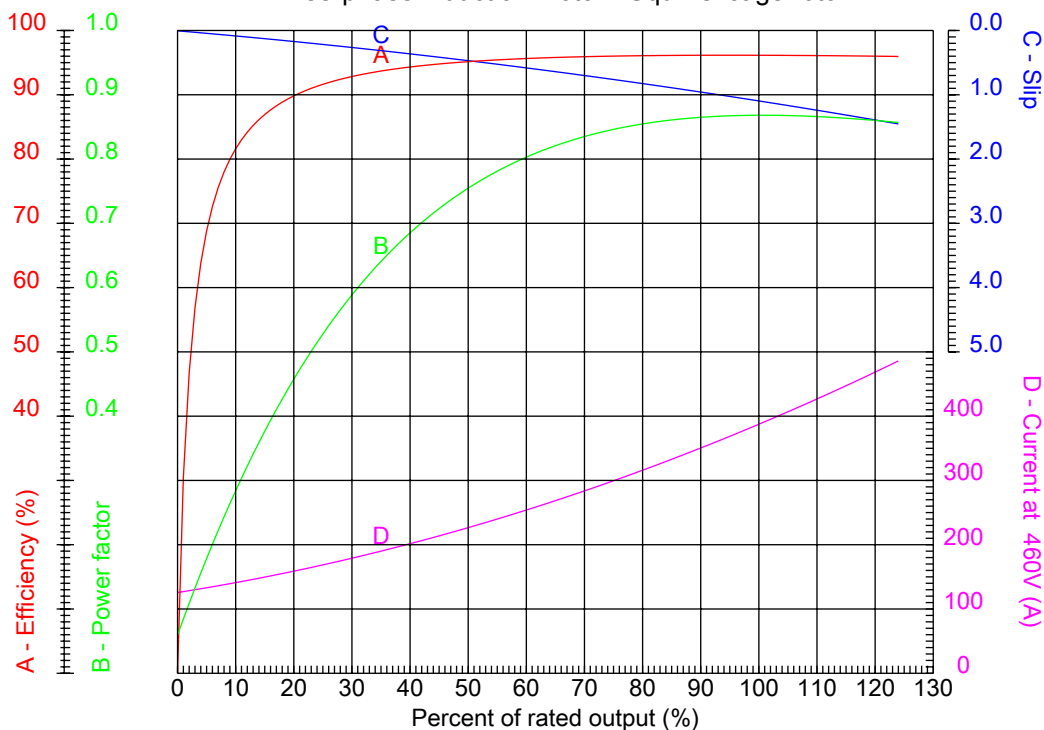

Customer :
Product line : Three-Phase : Explosion Proof - NEMA Premium

Frame : 449T	Locked rotor current (I _l /I _n) : 7.8
Output : 350 HP	Duty cycle : S1
Frequency : 60 Hz	Service factor : 1.15
Full load speed : 1780	Design : A
Voltage : 460 V	Locked rotor torque : 280 %
Rated current : 390 A	Breakdown torque : 290 %
Insulation class : F	

Notes:

Performed by

Checked



No.:

Date: 28-DEC-2012

CHARACTERISTIC CURVES RELATED TO SPEED

Three-phase induction motor - Squirrel cage rotor

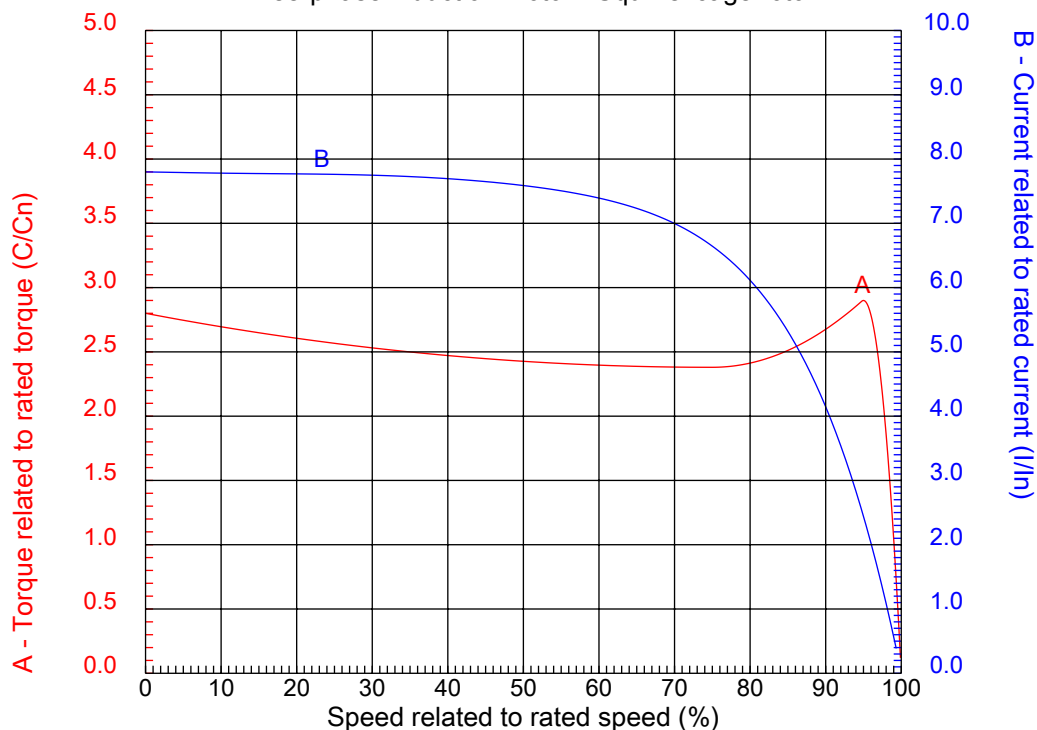

Customer :
Product line : Three-Phase : Explosion Proof - NEMA Premium

Frame	: 449T	Locked rotor current (I _l /I _n)	: 7.8
Output	: 350 HP	Duty cycle	: S1
Frequency	: 60 Hz	Service factor	: 1.15
Full load speed	: 1780	Design	: A
Voltage	: 460 V	Locked rotor torque	: 280 %
Rated current	: 390 A	Breakdown torque	: 290 %
Insulation class	: F		

Notes:

Performed by

Checked

1 2 3 4 5 6 7 8

A

B

C

D

E

F

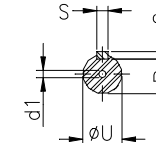
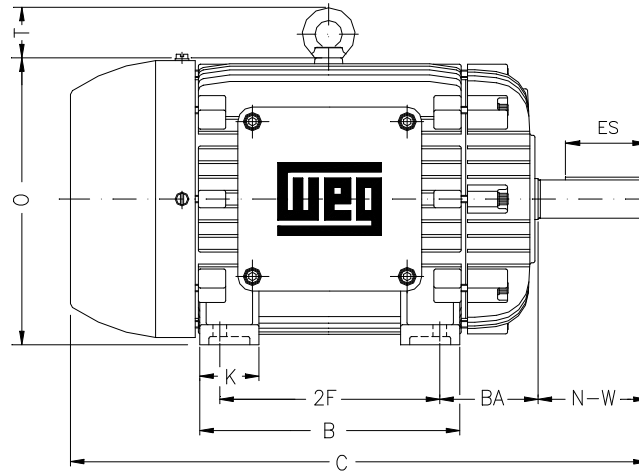
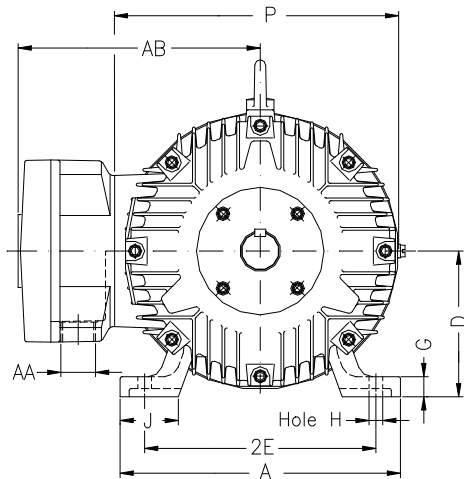

Notes:

Performed by:

Checked:

Customer:

Three-Phase : Explosion Proof - NEMA Premium

Three-phase induction motor
Frame 449T - IP54

28-DEC-2012



2E 18.000	A 21.929	2F 25.000	B 32.126	BA 7.500
J 3.937	K 7.104	P 24.016	ES 7.087	depth 0.875
S 0.875	N-W 8.500	U 3.375	R 2.880	AB 20.984
D 11.000	G 1.630	O 23.622	HD 27.165	H 0.807
C 54.996	AA 2XNPT 3"	d1 DUNC 3/4"-10	d2 DUNC 3/4"-10	T 3.543
Flange FD-508	AJ 20.000	AK 18.000	BD 21.656	BF 18.000
BB 0.203				