



UNIDOOR

SHOWER DOOR INSTALLATION INSTRUCTIONS

IMPORTANT

DreamLine™ reserves the right to alter, modify or redesign products at any time without prior notice. For the latest up-to-date technical drawings, manuals or any other details please refer to the support.BathAuthority.com web page.

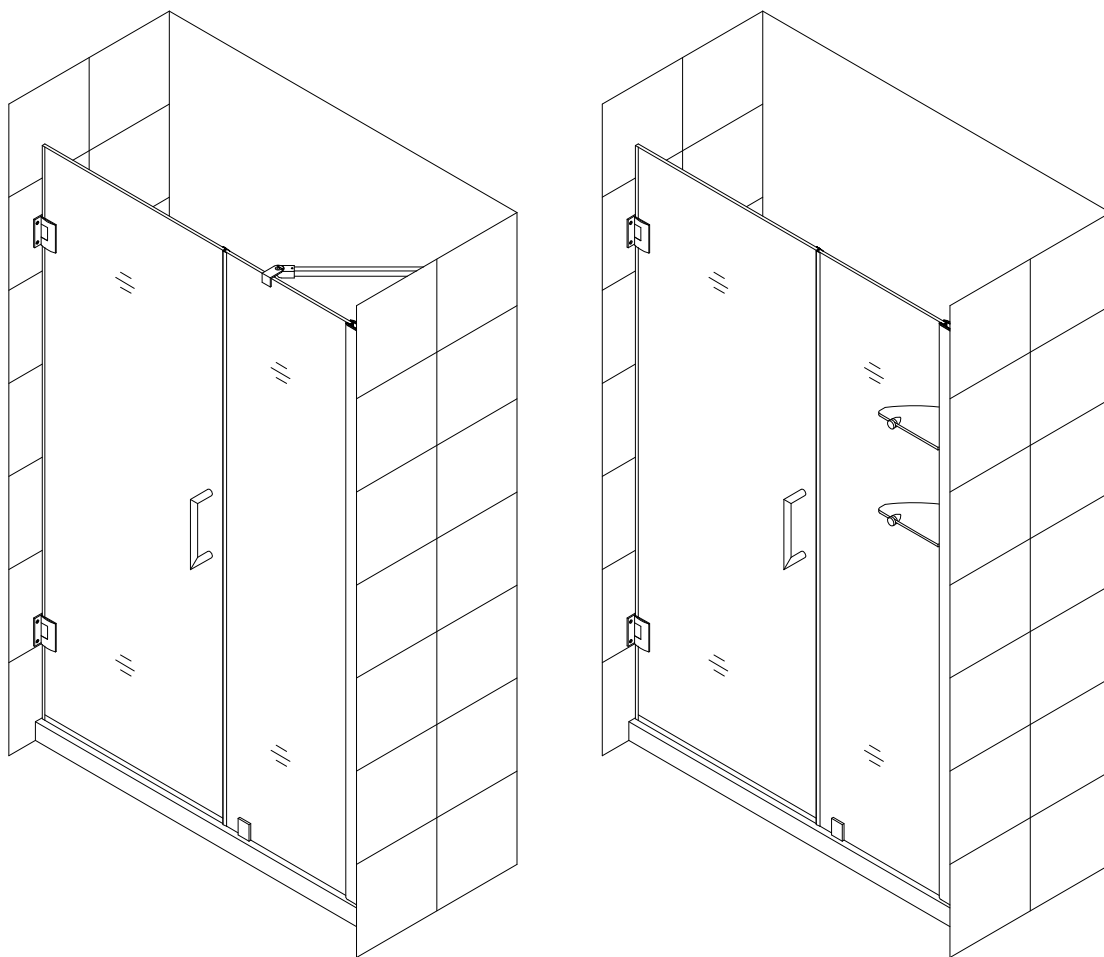

Please read these instructions carefully before installing. If you have any questions regarding installation, please call our technical support specialists Monday through Friday 9:00 AM – 5:00 PM EST at Phone: [1-866-731-2244](tel:1-866-731-2244), Fax: [1-866-227-1533](tel:1-866-227-1533) or e-mail our technical support group at support@BathAuthority.com.

For more information on [DreamLine™ Shower Doors](http://www.BathAuthority.com) please visit www.BathAuthority.com

Preparation

1. After opening all boxes and packages, read this introduction carefully. Check that all of the needed parts are included in the package by marking all the components on the "Detailed Diagram of Shower Door Components". Examine boxes and packages for shipping damage. If the unit has been damaged, has a finishing defect, or has missing parts, please contact our customer support department within 5 business days of the delivery date. Please note that **DreamLine™ will not replace any damaged products or missing parts free of charge after 5 business days or if the product has been installed.** Feel free to contact DreamLine™ if you have any questions.
2. **Please note that you should consult your local building codes with questions on installation compliance standards. Building and plumbing codes may vary by location, and DreamLine is not responsible for code compliance standards for your project and will not accept any returns.**
3. If this unit is going to be installed in a new construction, please, install all of the required plumbing and drainage before installing the shower. **Use a competent and licensed (if required by local code) plumber for all plumbing installation**
4. Prior to the installation, please ensure that the installation surface is level and solid and will be able to support the total weight of the unit. Also make sure that the walls are plumb. Depending on the type of unit you are installing, some adjustments in leveling may be possible. However, irregular installation, surface level or out of square conditions can result in serious problems for your installation. Please note that some adjustments and drilling may be necessary. Please protect all primary surfaces of the product during installation. **Never set your glass down directly onto a tile floor.** Always use a piece of wood or cardboard to protect the bottom edge and corners of the glass.
5. **Please, NOTE! The doors that are under 30" do not have out-of-plumb adjustment. Make sure your walls are at right angles**
6. a) If the width of your door is less than **30"** and you are installing the door without stationary glass, you only need to refer to **(Diagram A)** with **(Packing List A)**.
- b) If the width of your door is **30"** and over, and you are installing the door and stationary glass with support arm, you have to use **(Diagram A and B)** with **(Packing List A and B)** to complete the installation
- c) If the width of your door is **30"** and over, and you are installing the door and stationary glass with glass shelves, you have to use **(Diagram A, and C)** with **(Packing List A, and C)** to complete the installation

Tools Required

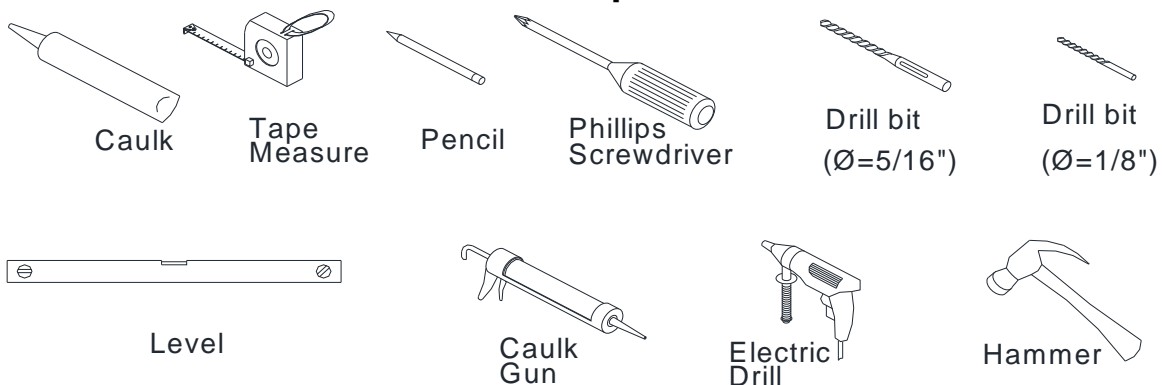

Detailed Diagrams of Shower Door Components

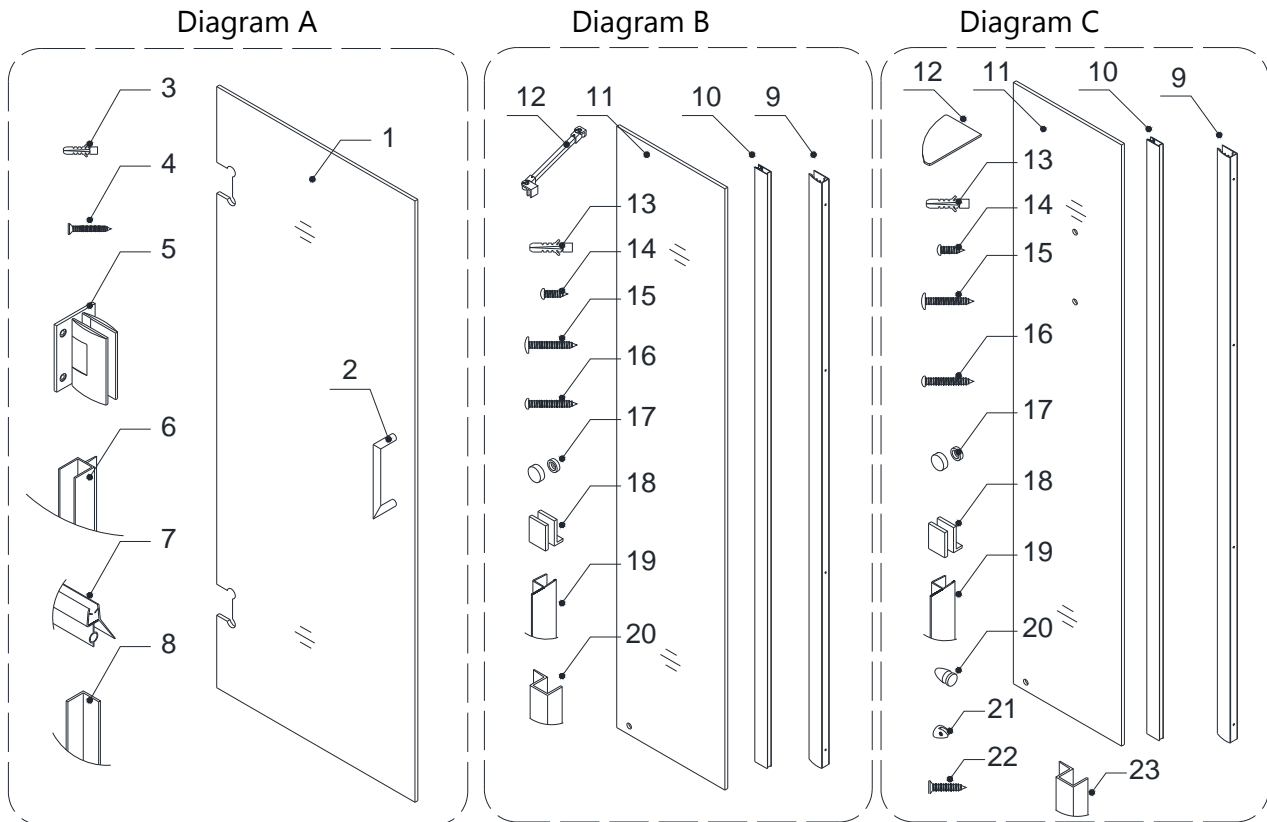

*** ATTENTION:** All parts that marked with the star (*), not provided with 6" Stationary panel.

Packing List A					
01	Glass door	1pc	05	Hinge	2pcs
02	Handle	1pc	06	Side strip (3 sections to cut)	1pc
03	Wall Anchor	8pcs	07	Bottom anti-water strip	1pc
04	Countersunk screw ST5x50	8pcs	08	L-shaped strip	1pc
Packing List B					
09	Wall profile	1pc	15	Round head screw ST4.2x40	4pcs+1pc*
10	Glass profile	1pc	16	Round head screw ST4.2x25	1pc
11	Stationary glass	1pc	17	Decorative screw cover	4pcs
12*	Support bar	1pc	18	Bottom bracket	1pc
13	Wall Anchor	4pcs+1pc*	19	Anti-Water strip (Door)	1pc
14	Round head screw ST4.2x10	3pcs	20	Anti-Water strip (Enclosure)	1pc
Packing List C					
09	Wall profile	1pc	17	Decorative screw cover	4pcs
10	Glass profile	1pc	18	Bottom bracket	1pc
11	Stationary glass	1pc	19	Anti-Water strip (Door)	1pc
12*	Glass shelf	2pc	20*	Shelf bracket (with nut)	2pcs
13	Wall anchor	4pcs+4pcs*	21*	Shelf bracket (without nut)	4pcs
14	Round head screw ST4.2x10	3pcs	22*	Countersunk screw ST4.2x25	4pcs
15	Round head screw ST4.2x40	4pcs	23	Anti-Water strip (Enclosure)	1pc
16	Round head screw ST4.2x25	1pc			

NOTE: Unpack your unit carefully and inspect it. Lay it out and identify all parts using parts diagram and part list in your manual as a reference. Before discarding the carton, check for small hardware bags that tend to fall to the bottom of the box. If any parts are damaged or missing, please contact DreamLine™ for replacement.

NOTE: Retain these installation instructions for future reference.

Shower Door Installation

1. Attach the **Hinges (05)** to the **Glass door (01)**.

See Fig. 1 for details.

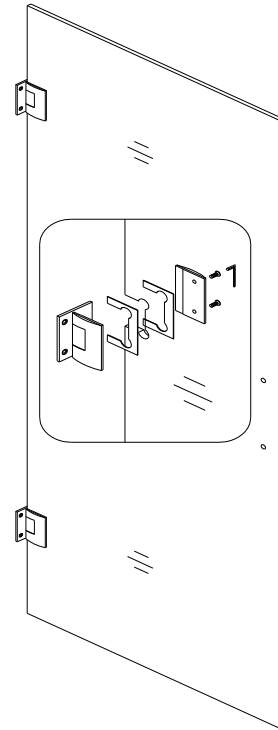

Fig. 1

2. Place a piece of flat timber (5/8" thick) on the threshold or the shower base. Take the **Glass door (01)** and place it on the flat timber. Butt up the door with hinged side against the wall, adjust its position and level it.
Be sure the door is absolutely vertical.

See Fig. 2 for details.

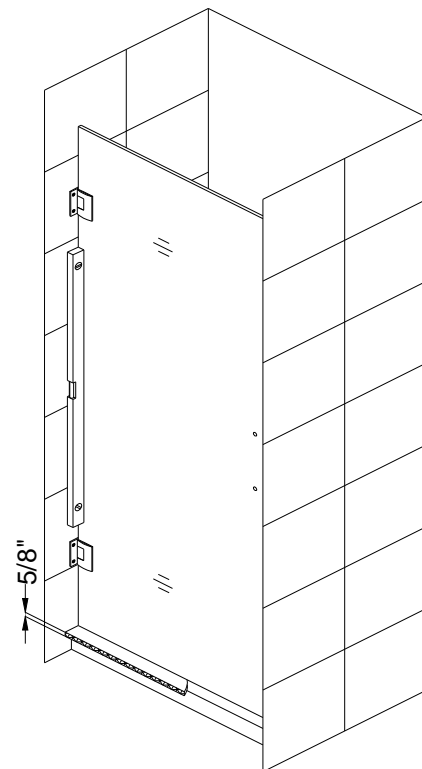

Fig. 2

3. Mark the drill holes for both hinges on the wall. Set the door aside, drill the holes in the wall using $\varnothing 5/16''$ drill bit, and insert the **Wall Anchors (03)**.

Place the **Glass door** back on the flat timber and attach both hinges to the wall with the **Countersunk screws ST5×50 (04)**.

See Fig. 3 for details.

PLEASE NOTE:

The manufacturer strongly recommends to attach this heavy door to the studs or to preinstalled 2x6 wood reinforcement behind the wall.

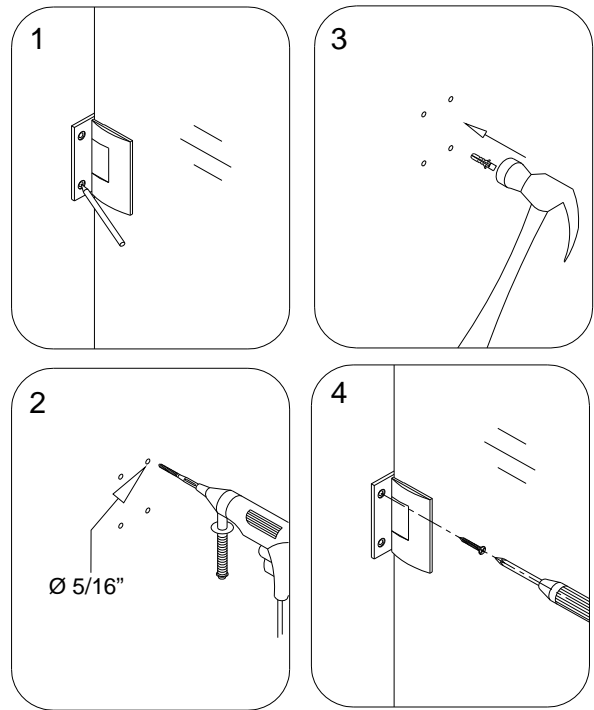

Fig. 3

4. Get three measurements:

- from the top edge of the **Glass door (01)** to the upper edge of the top **Hinge (05)**;
- from the bottom edge of the upper **Hinge** to the top edge of the bottom **Hinge**;
- from the bottom edge of the bottom **Hinge** to the bottom of the **Glass door**.

Cut the **Side strip (06)** according to the measurement.

Remove the timber plate, open the door to its full section and press the cut strips on the vertical edge of the **Glass door**.

Press the **Bottom anti-water strip (07)** on the bottom edge of the glass door.

See Fig. 4 for details.

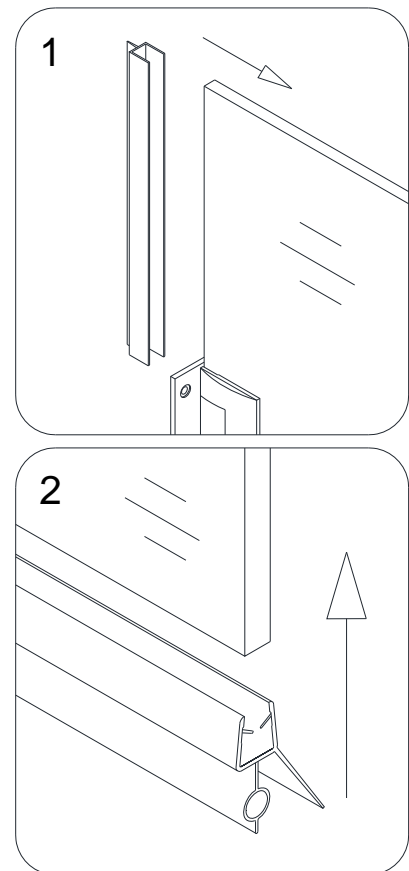

Fig. 4

5. Mount the **Handle (02)** to the **Glass door (01)**.

See Fig. 5.1 for details.

ATTENTION:

Prior to the next step, please be sure the part of the wall for installation of the L-shaped strip (08) is clean, dry and free from soap, oil and any construction debris.

6. With the door closed place the **L-shaped strip (08)** on the door edge and mark its location on the wall.

Please note that the corner of the L-shaped strip (08) should face inward.

Open the door. Gently remove the plastic tape from the adhesive side of the **L-shaped strip (08)** and firmly press it to the wall.

See Fig. 5.2 and Fig. 5.3 for details.

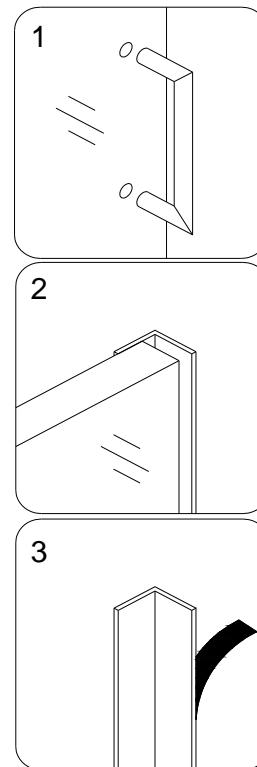

Fig. 5

NOTE:

If your shower door is up to 30" in width and you don't have the Stationary glass, you only need to assemble parts from Packing List A and your installation is finished.

See Fig. 6 for details.

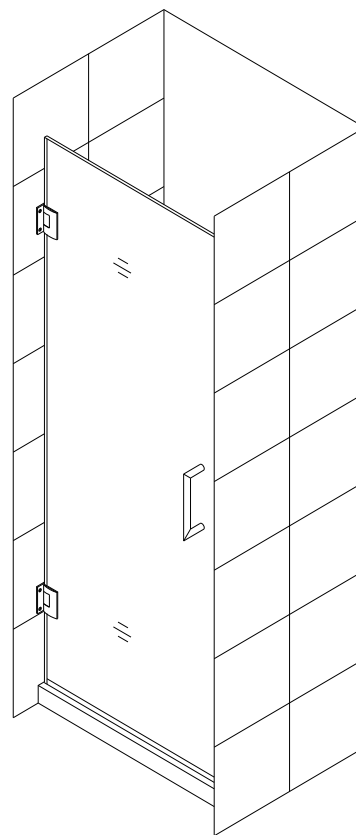

Fig. 6

NOTE:

If your door is more than 30" in width, you will need to add Stationary glass panel (11):

- a) For installation of the **Stationary Glass with Support bar**, you will need to refer to **Packing List B**.
- b) For installation of the **Stationary Glass with Glass Shelves**, you will need to refer to **Packing List C**.

See Fig. 7 for details.

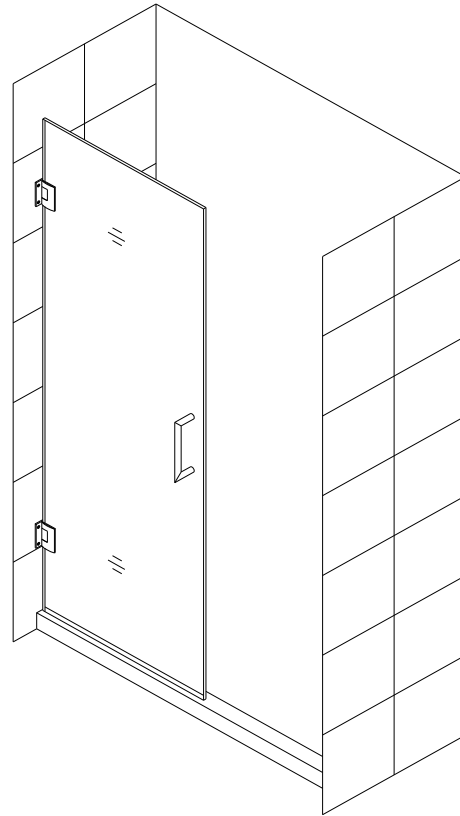

Fig. 7

Stationary Glass Installation

7. Apply clear silicone along the inner channel of the **Glass profile (10)** and push the **Stationary glass (11)** inside the channel.

NOTE: If you have difficulty sliding the Glass profile over the Stationary glass, you can slightly tap on the Glass profile with a rubber hammer and a piece of wood.

See Fig. 8.1, Fig. 8.2 and Fig. 8.3 for details.

NEVER use the metal hammer or hit the profile without the wood bumper.

8. Push the **Glass profile (10)** inside the **Wall profile (09)**.

See Fig. 8.4 for details.

NOTE: Please note that the hole in the corner of the Glass panel should be at the bottom, farther from the wall.

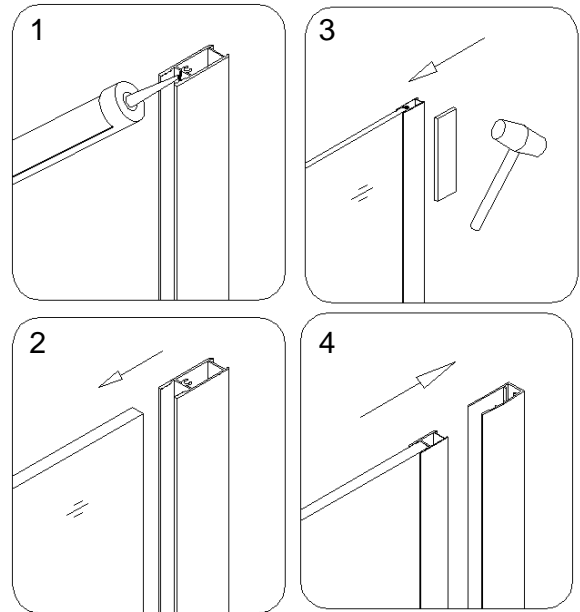

Fig. 8

9. Press the **Anti-Water strip (19)** on the vertical edge of the **Stationary glass (11)**. Align the **Stationary glass** with the **Glass Door (01)** and then close the **Glass door**.

If needed adjust the position of the **Stationary glass** to make sure the **Anti-water strip (19)** and the **Glass door (01)** work well.

See Fig. 9 for details.

Please note: The Stationary glass must be leveled with the Glass door

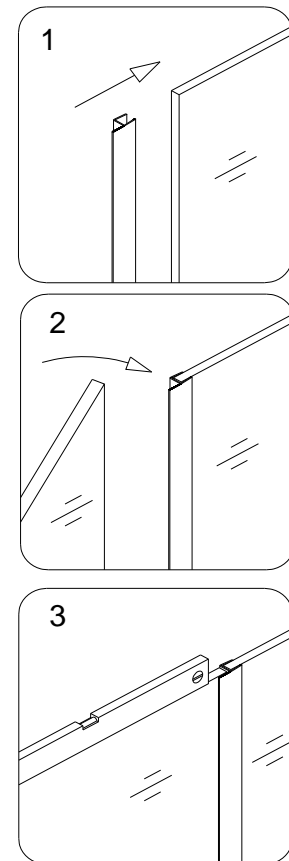

Fig. 9

10. Draw a line along the inner edge of the **Wall profile (09)** on the wall. Detach the **Wall profile** from the **Stationary glass (11)** and the **Glass profile (10)** assembly. Place the **Wall profile** to the outlined position and mark the drilling holes through the predrilled holes in the **Wall profile**.

Now drill the holes using $\text{Ø } 5/16''$ drill bit in the wall and insert the **Wall anchors (13)** into the holes.

Apply silicone along the **Wall profile** and around the holes. Fasten the **Wall profile** to the wall with the **Round head Screw ST4.2×40 (15)**. Then push the **Stationary glass** and **Glass profile** assembly into the **Wall profile**.

See Fig. 10 for details.

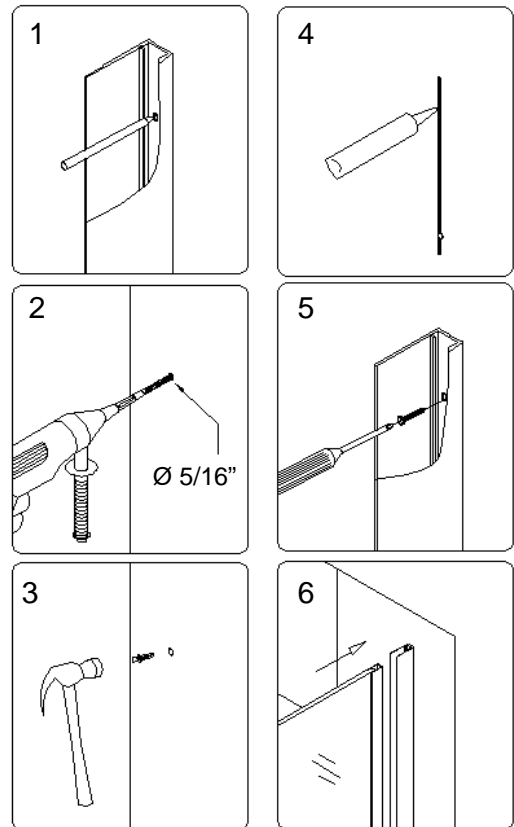

Fig. 10

11. Adjust the **Stationary glass (11)** position to ensure that when the glass door is closed, there is a gap ($1/16''-1/8''$) between the two glass panels.

To adjust and secure the stationary glass in place, install the **Bottom Bracket (18)** to the **Stationary glass**;

Mark the drilling hole for the bracket. Make sure the mark is clear and visible and drill the hole using $\text{Ø } 1/8''$ drill bit.

Use the **Round head screws ST4.2×25 (16)** to attach the **Bottom Bracket** to the shower base or the threshold. Cover the screw head with **Decorative screw cover (17)**.

See Fig. 11 for details.

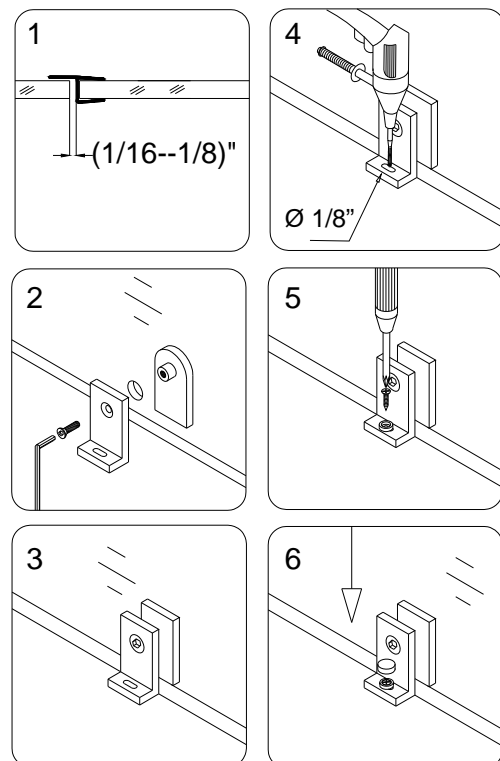

Fig. 11

12. After final adjustments of the **Stationary glass (11)** drill the holes in the **Glass profile (10)** through predrilled holes in the **Wall profile (09)** using $\varnothing 1/8''$ drill bit.

NOTE: You only need to drill through the first layer of the **Glass Profile**.

Use **Round head screws ST4.2×10 (14)** to attach the **Wall profile** to the **Glass profile**. Cover the exposed screw heads with **Decorative screw cover (17)**.

See Fig. 12 and Fig. 13 for details.

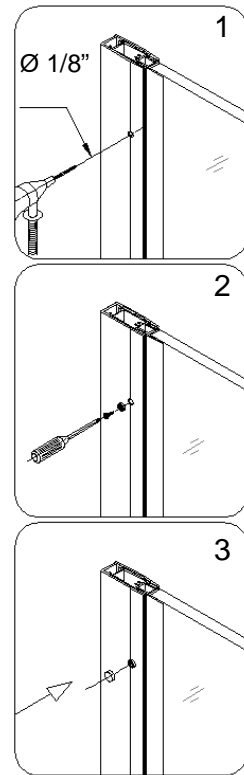

Fig. 12

If the Stationary Panel width is 6", the installation is finished.

If the Stationary Glass width is 12" and over you will need to continue your installation from:

- a) **Step 13 for Support Bar installation.**
- b) **Step 15 for Glass Shelves installation.**

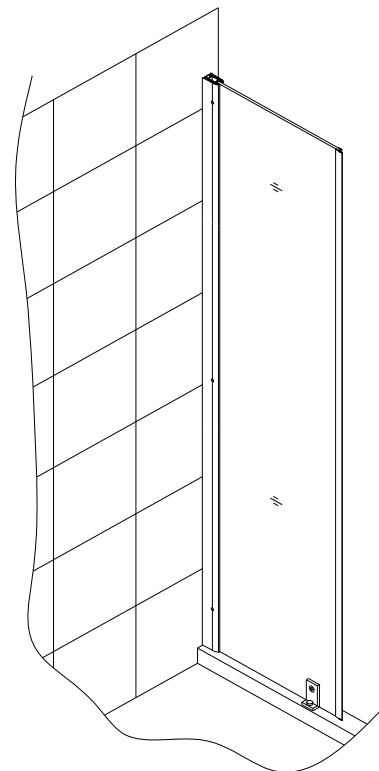

Fig. 13

Support bar installation

13. Locate the **Support bar (12)**.

Adjust the bar to a proper position on the glass and the wall. Level it horizontally. Hold it firmly and outline the bracket's position on the wall. Remove the **Support bar** and detach the wall bracket from it. Place the wall bracket against its outlined position on the wall and mark the drilling hole.

Drill the hole using $\text{Ø } 5/16''$ drill bit, insert the **Wall anchor (13)** and fasten the wall bracket to the wall with the **Round head screws ST4.2×40 (15)**. Attach the **Support bar** to the wall as shown on Fig 14.5 and tighten the set screws and the glass holding screw to secure the glass.

See Fig. 14 for details.

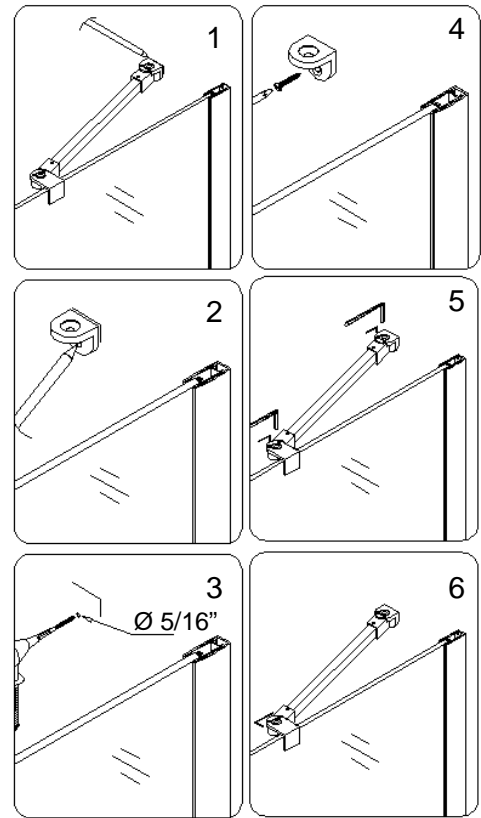

Fig. 14

14. Apply the sealant along the connection of the **Stationary glass** and the Shower base or threshold.

See Fig. 15 for details.

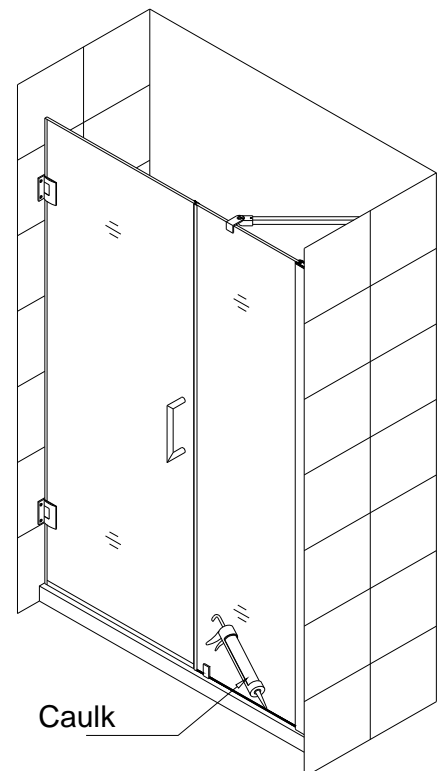

Fig. 15

Glass shelves installation

15. Mark the **Glass shelf (12)** position on the wall. According to the measurements in Fig. 16.1, mark the drilling holes for the **Shelf brackets (21)**.

Drill the holes using $\varnothing 5/16''$ drill bit and insert the **Wall anchors (13)**.

Attach the **Shelf brackets (without nut) (21)** to the wall using the **Countersunk screw ST4.2×25 (22)** and attach the **Shelf brackets (with nut) (20)** to the **Stationary glass (11)**.

Insert the **Glass shelves** into the **Shelf brackets** and fasten the screws at the bottom of the brackets.

See Fig. 16 and Fig. 17 for details.

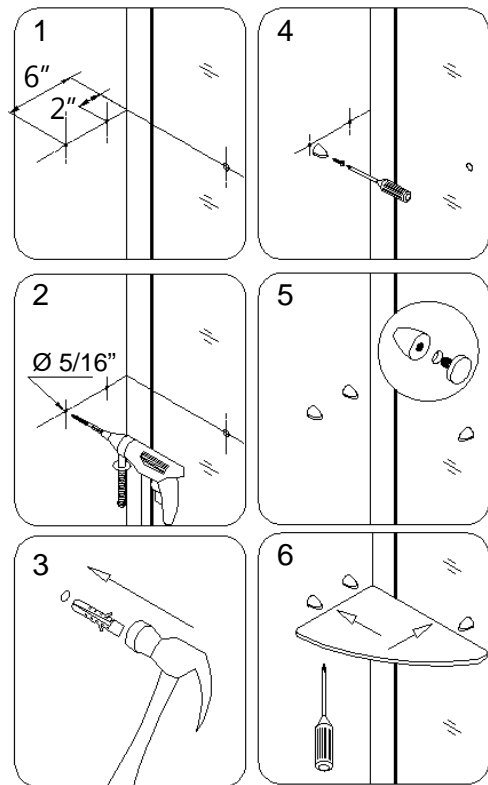

Fig. 16

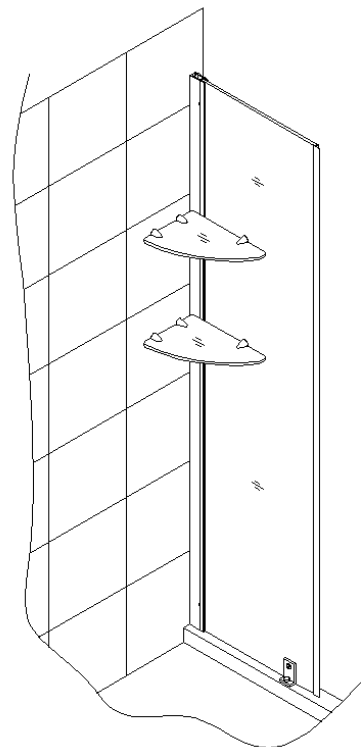

Fig. 17

16. Apply the sealant along the connection of the **Stationary glass** and the Shower base or the threshold.

See Fig. 18 for details.

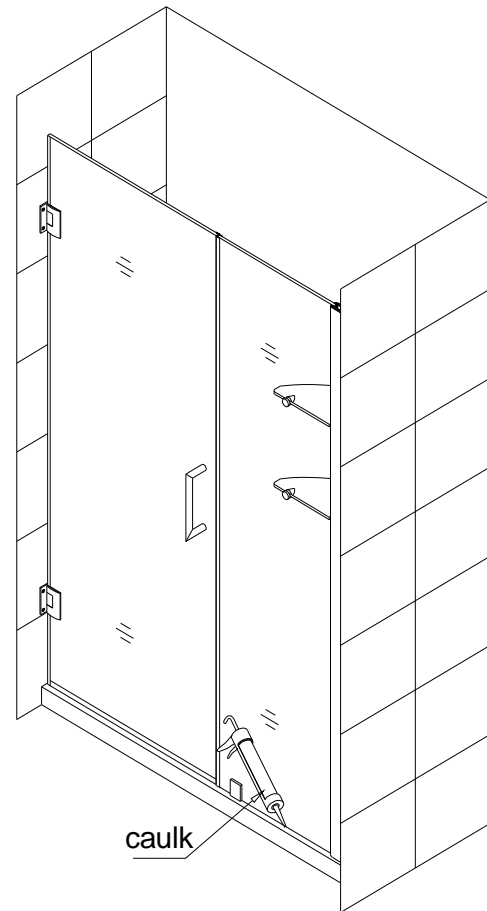

Fig. 18

Maintenance

To insure long lasting life for your acrylic back walls, wipe them off after each use with a soft cloth. To clean the acrylic back walls use non-abrasive sprays or cream based cleaners. Never use abrasive cleansers, metal brushes or scrapers that could scratch or dull the surface.

To insure long lasting life for your glass shower products, wipe them off after each use with a soft cloth. Rinse and wipe of the glass using either soft cloth or squeegee to prevent soap buildup. Never use abrasive cleaners and cleaning products that contain scoring agent because this may scratch the surface. Never use bristle brushes or abrasive sponges.

To assure a long lasting finish wipe off the metal parts after each use with a soft cloth. Do not use abrasive cleaners or cleaning products containing ammonia, bleach or acid. If accidentally used, rinse the surface as soon as possible to prevent finish peeling or corrosion. After cleaning the shiny finishes, rinse thoroughly and wipe dry with soft cloth. Clean stainless steel surfaces at least once a week. When applying stainless steel cleaner or polish, work with (not across) the grain. Never use abrasive sponge or cloth, steel wool or wired brushes.

DREAMLINE™ EXCLUSIVE LIMITED WARRANTY AS OF MAY 6, 2013

This warranty extends only to the original owner/end-user for household use only and is not transferable to a subsequent owner. This warranty extends for a designated period of time, so long as it remains in use in its original place of installation. This warranty applies only to DreamLine products purchased from an authorized dealer in United States or Canada. Proof of purchase (original sales receipt) from the original consumer purchase must be provided with all warranty claims.

IN NO EVENT SHALL THE LIABILITY OF DREAMLINE EXCEED THE PURCHASE PRICE OF THE UNIT.

DreamLine products must be installed by a fully insured and licensed professional. Installation of DreamLine product by anyone other than fully insured licensed professionals shall **VOID THE WARRANTY**. DreamLine recommends that such licensed professionals have experience in the installation of bathroom products. Installation of certain products, including, without limitation, glass products (i.e., shower and tub doors) by an inexperienced installer may result in glass breakage and, consequently, cause personal injury or death.

PARTS ONLY WARRANTY

This warranty is extensive in that it covers replacement of all defects. LABOR CHARGES AND/OR DAMAGE INCURRED IN INSTALLATION, REPAIR, OR REPLACEMENT, AS WELL AS ANY OTHER KIND OF LOSS OR DAMAGE ARE EXCLUDED

COMMERCIAL USE AND OTHER EXCLUSIONS

This warranty excludes all industrial, commercial and business usage, whose purchasers are hereby extended a one (1) year limited warranty from the date of purchase for shower and tub doors, a three (3) month limited warranty from the date of purchase for vanities and sinks, with all other terms of this warranty applying except the duration of the warranty.

DREAMLINE JETTED AND STEAM SHOWER CABINS, DREAMLINE SHOWER COLUMNS AND DREAMLINE SHOWER SEATS ARE NOT INTENDED FOR COMMERCIAL USE AND THERE IS NO WARRANTY EXTENDED FOR THESE PRODUCTS FOR COMMERCIAL USE.

DreamLine hereby disclaims all warranties for products sold as dealer or store displays. DreamLine hereby disclaims all warranties for products used outside of the United States or Canada whether expressed or implied, including but not limited to the implied warranties of merchantability and fitness for a particular purpose.

WARRANTY TERMS

DreamLine will, at its election, repair or replace the product found by DreamLine in its sole judgment, to be defective within the warranty period under normal residential use and maintenance. The replacement of a product is limited to supplying a replacement product or part (same as existing or if not available, comparable product). DreamLine warranty obligation shall be discharged upon tender of parts, replacement or repair of the product. Purchaser's refusal to accept the tender terminates all warranty obligations and **VOIDS THE WARRANTY**. Cost of freight for returning products to DreamLine for repairs or replacement under this limited warranty are the responsibility of the customer. Cost of freight associated with shipping of replacement product or parts to the customer may be charged to customer. Any product replaced or repaired during the warranty period will be covered only for the remaining period of the original warranty. In no event will DreamLine be liable for costs of repair or replacement of any installation material, including but not limited to tiles, marble, etc.

DREAMLINE IS NOT RESPONSIBLE FOR INSTALLATION, REMOVAL OR REINSTALLATION COSTS OF ANY PRODUCT REQUIRING WARRANTY SERVICES.

Any modification or alteration of any DreamLine products will void the warranty. DreamLine product installations and repairs must be performed by either a DreamLine authorized agent or a licensed, insured and experienced professional contractor - installation or repairs performed by any other party shall void the warranty. This warranty shall not apply to breakage or damages caused by normal wear and tear, fault, carelessness, abuse, misuse, misapplication, improper maintenance, alteration or modification of the unit, as well as chemical or natural corrosion, accident, fire, flood, act of God or any other casualty. Improper care and cleaning will void the warranty. Use of cleaners containing abrasive cleansers, ammonia, bleach, acids, waxes, alcohol, solvents or other products not recommended for chrome or similar finish, glass or acrylic will void the warranty. For additional product maintenance instructions please refer to product installation manual. DreamLine is not responsible for any issues arising in connection with errors or omissions in information provided on DreamLine's websites. The warranty does not extend to any non-DreamLine plumbing or components installed by installers, end users or by any party other than DreamLine.

THE FOREGOING WARRANTIES ARE IN LIEU OF ALL OTHER WARRANTIES, EXPRESSED OR IMPLIED, INCLUDING BUT NOT LIMITED TO THE IMPLIED WARRANTIES OF MERCHANTABILITY AND FITNESS FOR A PARTICULAR PURPOSE. BATH AUTHORITY LLC ("DREAMLINE") AND/OR SELLER DISCLAIMS ALL LIABILITY FOR SPECIAL, INCIDENTAL OR CONSEQUENTIAL DAMAGES. DREAMLINE IS NOT LIABLE FOR PERSONAL INJURIES OR DEATH TO ANY PERSON OR FOR ANY DIRECT, SPECIAL, INCIDENTAL OR CONSEQUENTIAL DAMAGE, LOSS OF USE, LOSS OF TIME, LOSS OF PROFITS, INCONVENIENCE, INCIDENTAL EXPENSES, LABOR OR MATERIAL CHARGES, OR ANY OTHER COSTS RESULTING FROM THE USE OF ITS PRODUCTS OR PERTAINING TO THE APPLICATION OF THE PRESENT WARRANTY, OR RESULTING FROM THE REMOVAL OR REPLACEMENT OF ANY PRODUCT OR ELEMENT OR PART COVERED BY THIS WARRANTY.

PRODUCT WARRANTY PERIODS

DreamLine is not responsible for product code compliance or for verifying building code restrictions on installation or use and any such compliance is excluded from this warranty. DreamLine reserves the right to modify this warranty at any time - such warranty modifications will not alter the warranty applicable at the time of sale of the products in question. The warranty terms for specific products for consumer (non-industrial, non-commercial, non-business use only) are:

SHOWER BACKWALL, SHOWER CABINS (JETTED & STEAM)

DreamLine warrants shower backwalls and shower cabins to be free from defects in workmanship for a period of one (1) year from initial date of purchase by the owner/end-user, contractor or builder from an authorized dealer.

SHOWER & TUB DOORS, SHOWER ENCLOSURES

DreamLine warrants shower doors, tub doors and shower enclosures to be free from defects in workmanship and materials under normal residential use for a period of five (5) years from the initial date of purchase by the owner/end-user, contractor or builder from an authorized dealer. Warranty for plastic strips shall be limited to one (1) year. Warranty for any part in Oil Rubbed Bronze finish shall be limited to one (1) year.

SHOWER BASES

DreamLine warrants shower bases to be free from defects in workmanship and materials under normal residential use for as long as the original consumer purchaser owns their home in which their product is installed.

SHOWER COLUMNS

DreamLine warrants shower columns to be free from defects in workmanship and materials under normal residential use for a period of one (1) year from the initial date of purchase by the owner/end-user, contractor or builder from an authorized dealer.

SHOWER SEATS

DreamLine warrants shower seats to be free from defects in workmanship and materials under normal residential use for a period of one (1) year from the initial date of purchase by the owner/end-user, contractor or builder from an authorized dealer. Warranty shall be VOID if the shower seat is not professionally installed on a properly reinforced wall.

VANITIES AND VESSEL SINKS

DreamLine warrants bathroom vanities and vessel sinks to be free from defects in workmanship and materials under normal residential use for a period of one (1) year from the initial date of purchase by the owner/end-user, contractor or builder from an authorized dealer.

STATE LAWS AND THIS WARRANTY

Some states/provinces do not allow limitations on how long an implied warranty lasts, or the exclusion or limitation of special, incidental or consequential damages, so these limitations and exclusions may not apply to you. This warranty gives you specific legal rights. You may also have other rights, which vary from state/province to state/province.

WARRANTY SERVICE

The following information will be required for you to file a Warranty claim:

1. Your name, address and telephone number
2. Product model number
3. Brief description of problem (please note that additional information such as photos may be required to fully process your warranty claim)
4. Proof of purchase

You may submit this information by e-mail, mail or fax to:

DreamLine
Warranty Service Center
75 Hawk Road
Warminster, PA 18974
F:1-866-857-3638
T:1-866-731-2244
Warranty@bathauthority.com



TEL: [866-731-2244](tel:866-731-2244)

FAX: [866-227-1533](tel:866-227-1533)

www.BATHAUTHORITY.COM

For more information on [DreamLine™ Shower Doors](http://www.BathAuthority.com) please visit www.BathAuthority.com