



No.:

Date: 24-DEC-2012

Customer :

TECHNICAL PROPOSAL

Three-phase induction motor - Squirrel cage rotor

Product line : Three-Phase : NEMA 56 Frames - ODP

Catalog Number : 00158OS3ED56

List Price : \$305

Notes:

Performed by:

Checked:



No.:

Date: 24-DEC-2012

DATA SHEET

Three-phase induction motor - Squirrel cage rotor

Customer :
Product line : Three-Phase : NEMA 56 Frames - ODP

Frame : D56
Output : 1.5 HP
Frequency : 60 Hz
Poles : 4
Full load speed : 1720
Slip : 4.44 %
Voltage : 208-230/460 V
Rated current : 4.70-4.42/2.21 A
Locked rotor current : 27.4/13.7 A
Locked rotor current (I_L/I_n) : 6.2
No-load current : 2.80/1.40 A
Full load torque : 4.52 lb.ft
Locked rotor torque : 220 %
Breakdown torque : 260 %
Design : A
Insulation class : B
Temperature rise : 80 K
Locked rotor time : 10 s (hot)
Service factor : 1.15 (1.00 at 208V)
Duty cycle : S1
Ambient temperature : -20°C - +40°C
Altitude : 1000
Degree of Protection : IP21
Approximate weight : 31 lb
Moment of inertia : 0.09041 sq.ft.lb
Noise level : ---

	D.E.	N.D.E.	Load	Power factor	Efficiency (%)
Bearings	6204 ZZ	6203 ZZ	100%	0.81	77.0
Regreasing interval	---	---	75%	0.72	76.0
Grease amount	---	---	50%	0.59	74.0

Notes:

Performed by

Checked



No.:

Date: 24-DEC-2012

PERFORMANCE CURVES RELATED TO RATED OUTPUT

Three-phase induction motor - Squirrel cage rotor

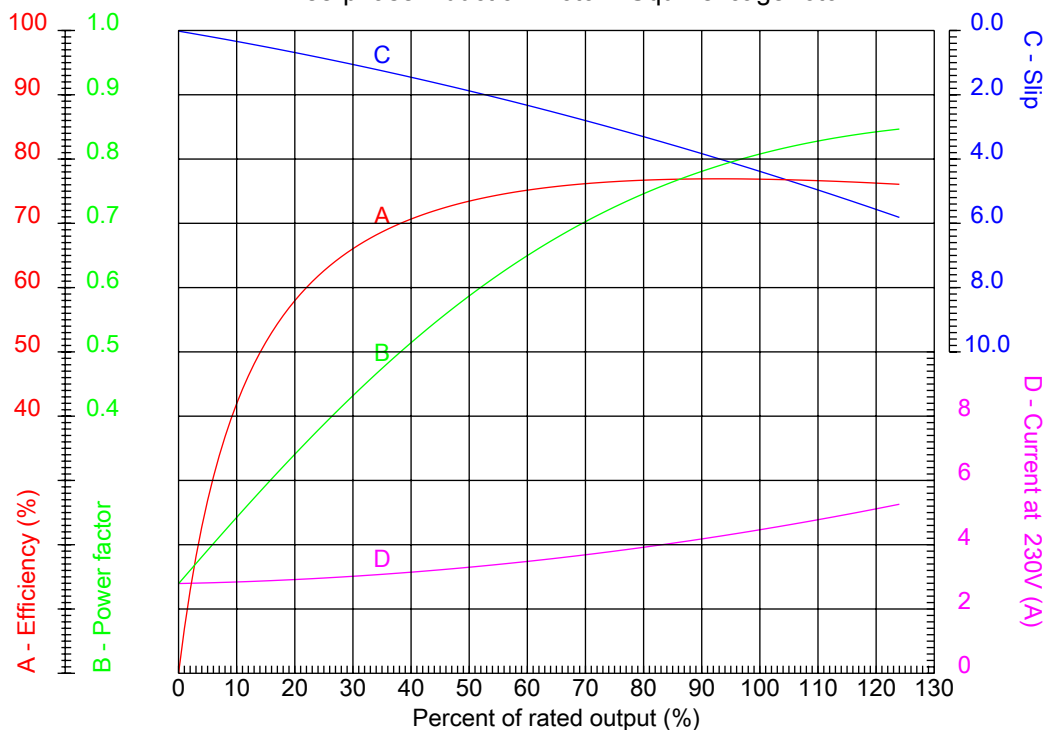

Customer :
Product line : Three-Phase : NEMA 56 Frames - ODP

Frame : D56	Locked rotor current (I _L /I _n) : 6.2
Output : 1.5 HP	Duty cycle : S1
Frequency : 60 Hz	Service factor : 1.15 (1.00 at 208V)
Full load speed : 1720	Design : A
Voltage : 208-230/460 V	Locked rotor torque : 220 %
Rated current : 4.70-4.42/2.21 A	Breakdown torque : 260 %
Insulation class : B	

Notes:

Performed by

Checked



No.:

Date: 24-DEC-2012

CHARACTERISTIC CURVES RELATED TO SPEED Three-phase induction motor - Squirrel cage rotor

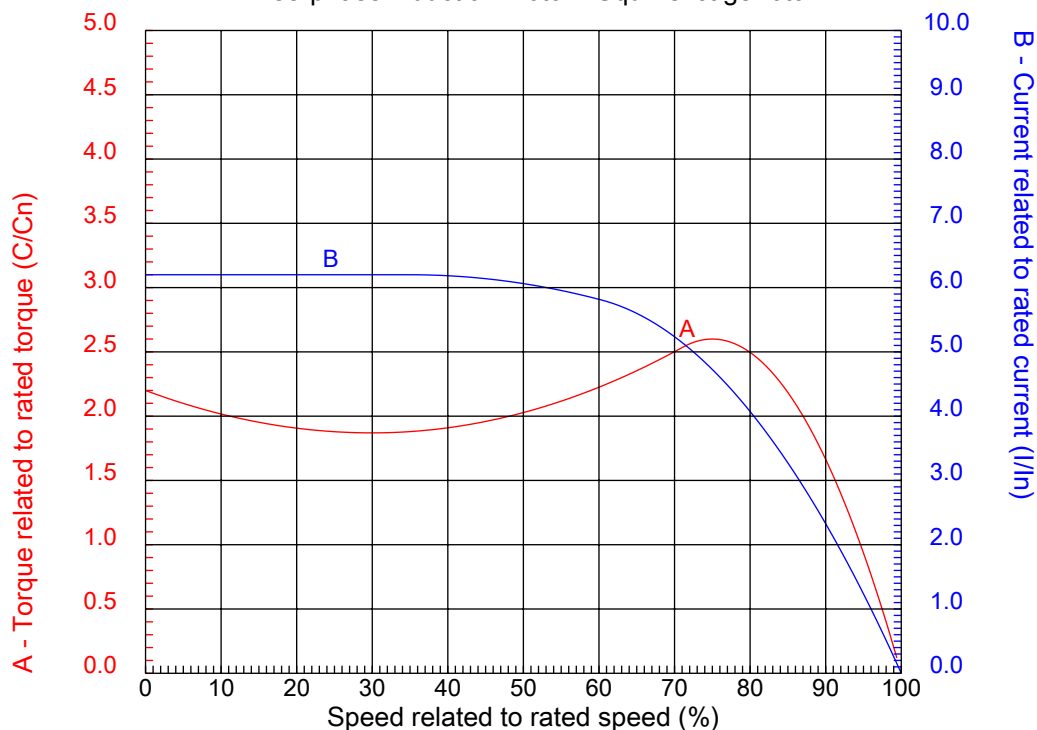

Customer :
Product line : Three-Phase : NEMA 56 Frames - ODP

Frame	: D56	Locked rotor current (I _l /I _n)	: 6.2
Output	: 1.5 HP	Duty cycle	: S1
Frequency	: 60 Hz	Service factor	: 1.15 (1.00 at 208V)
Full load speed	: 1720	Design	: A
Voltage	: 208-230/460 V	Locked rotor torque	: 220 %
Rated current	: 4.70-4.42/2.21 A	Breakdown torque	: 260 %
Insulation class	: B		

Notes:

Performed by

Checked

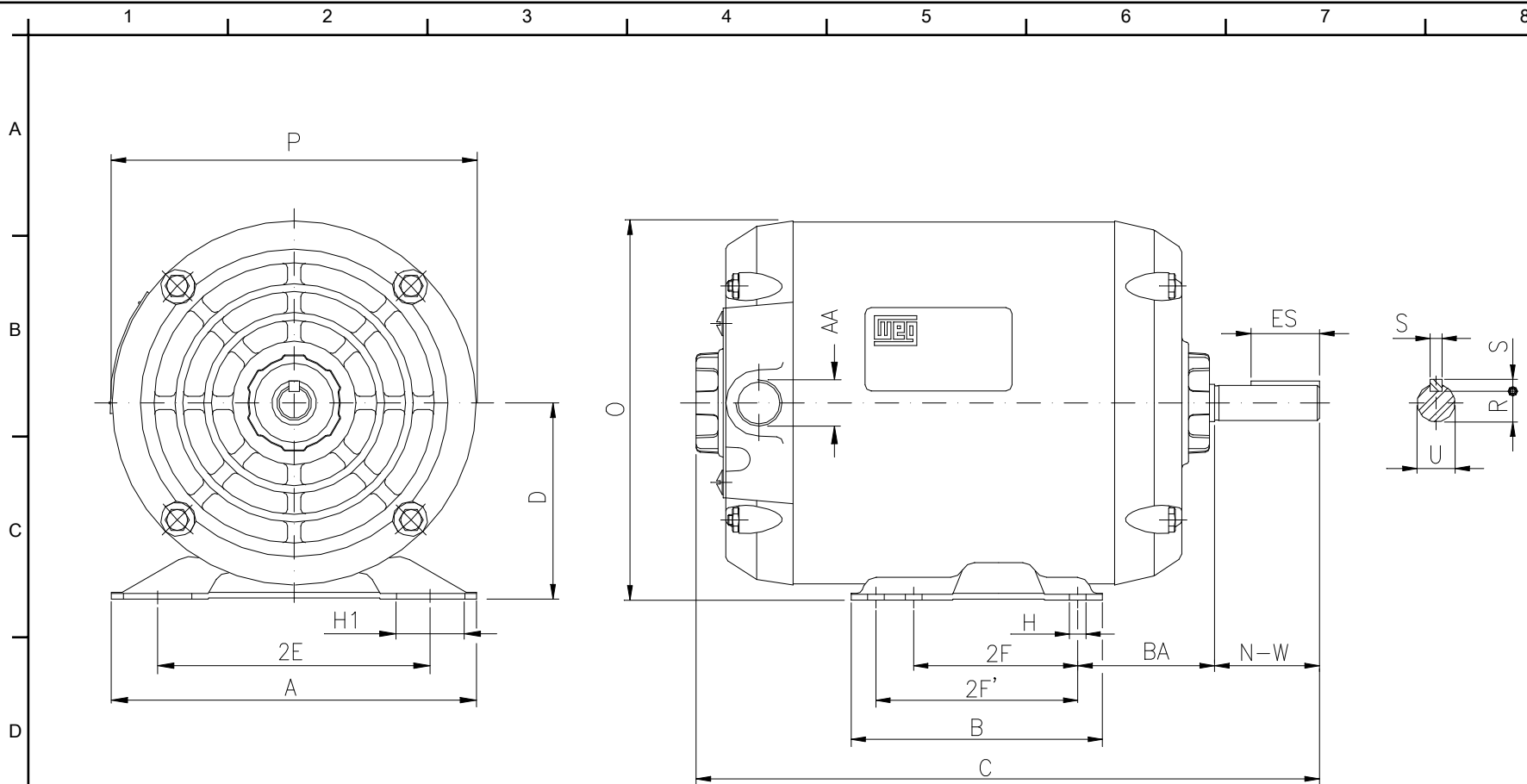

Notes:

Performed by:

Checked:

Customer:

Three-Phase : NEMA 56 Frames - ODP

Three-phase induction motor
Frame D56 - IP21

24-DEC-2012



2E 4.874	H 0.342	A 6.535	2F 3.000	B 4.016
G 3.04	BA 2.750	J 1.220	P 6.457	ES 1.102
S 0.187	N-W 1.874	depth 0.187	U 0.6250	R 0.517
D 3.500	O 6.732	T 1.929	HD 8.661	C 12.283
AA NPT 1/2"	Flange FC-95	AJ 3.748	AK 3.000	BD 5.630
BF UNC 1/4"x20-2B	BB 0.157	BC ---	AH 2.063	