



No.:

Date: 31-DEC-2012

Customer :

TECHNICAL PROPOSAL

Three-phase induction motor - Squirrel cage rotor

Product line : Cooling Tower Motors : High Efficiency - Two Speed

Catalog Number : 01089EP3PCT256V2

List Price : \$3,052

Notes:

Performed by:

Checked:



No.:

Date: 31-DEC-2012

DATA SHEET

Three-phase induction motor - Squirrel cage rotor

Customer :
Product line : Cooling Tower Motors : High Efficiency - Two Speed

Frame : 256T
Output : 2.5 HP
Frequency : 60 Hz
Poles : 8
Full load speed : 880
Slip : 2.22 %
Voltage : 200 V
Rated current : 15.0 A
Locked rotor current : 55.3 A
Locked rotor current (I_L/I_n) : 3.7
No-load current : 12.0 A
Full load torque : 14.7 lb.ft
Locked rotor torque : 220 %
Breakdown torque : 250 %
Design : A
Insulation class : F
Temperature rise : 80 K
Locked rotor time : 20 s (hot)
Service factor : 1.15
Duty cycle : S1
Ambient temperature : -20°C - +40°C
Altitude : 1000
Degree of Protection : IP55
Approximate weight : 309 lb
Moment of inertia : 2.9615 sq.ft.lb
Noise level : 54 dB(A)

	D.E.	N.D.E.	Load	Power factor	Efficiency (%)
Bearings	6309 2RS	6209 2RS	100%	0.48	74.0
Regreasing interval	---	---	75%	0.40	72.0
Grease amount	---	---	50%	0.31	64.0

Notes:

Performed by

Checked



No.:

Date: 31-DEC-2012

PERFORMANCE CURVES RELATED TO RATED OUTPUT

Three-phase induction motor - Squirrel cage rotor

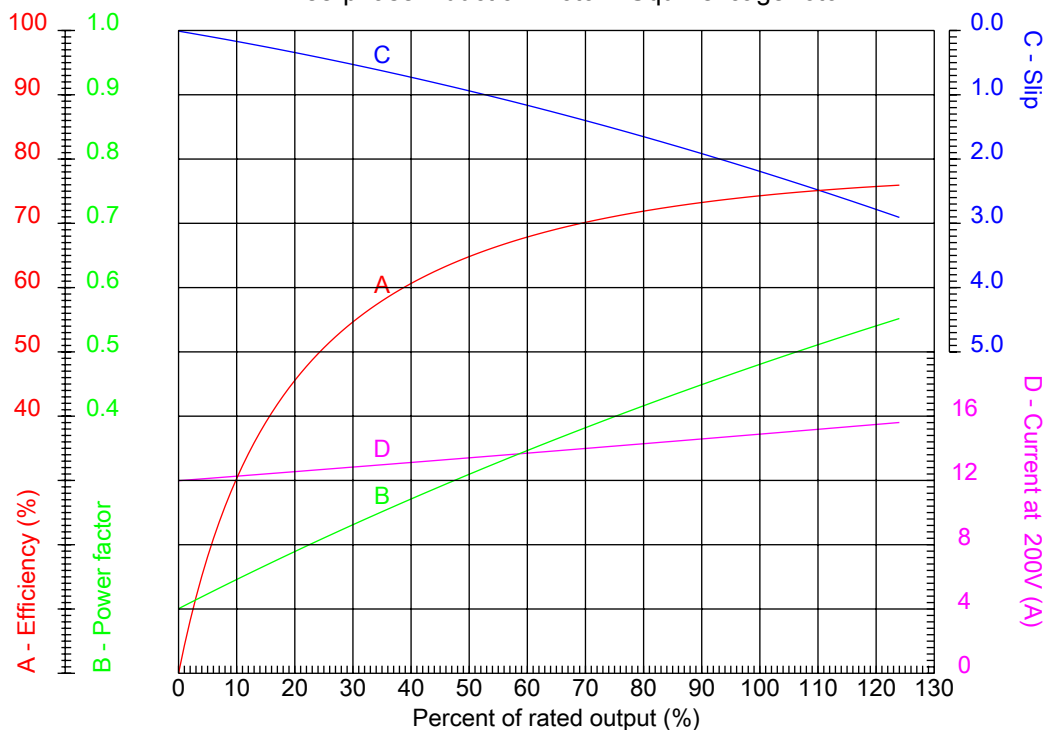

Customer :
Product line : Cooling Tower Motors : High Efficiency - Two Speed

Frame : 256T	Locked rotor current (I _l /I _n) : 3.7
Output : 2.5 HP	Duty cycle : S1
Frequency : 60 Hz	Service factor : 1.15
Full load speed : 880	Design : A
Voltage : 200 V	Locked rotor torque : 220 %
Rated current : 15.0 A	Breakdown torque : 250 %
Insulation class : F	

Notes:

Performed by

Checked



No.:

Date: 31-DEC-2012

CHARACTERISTIC CURVES RELATED TO SPEED
Three-phase induction motor - Squirrel cage rotor

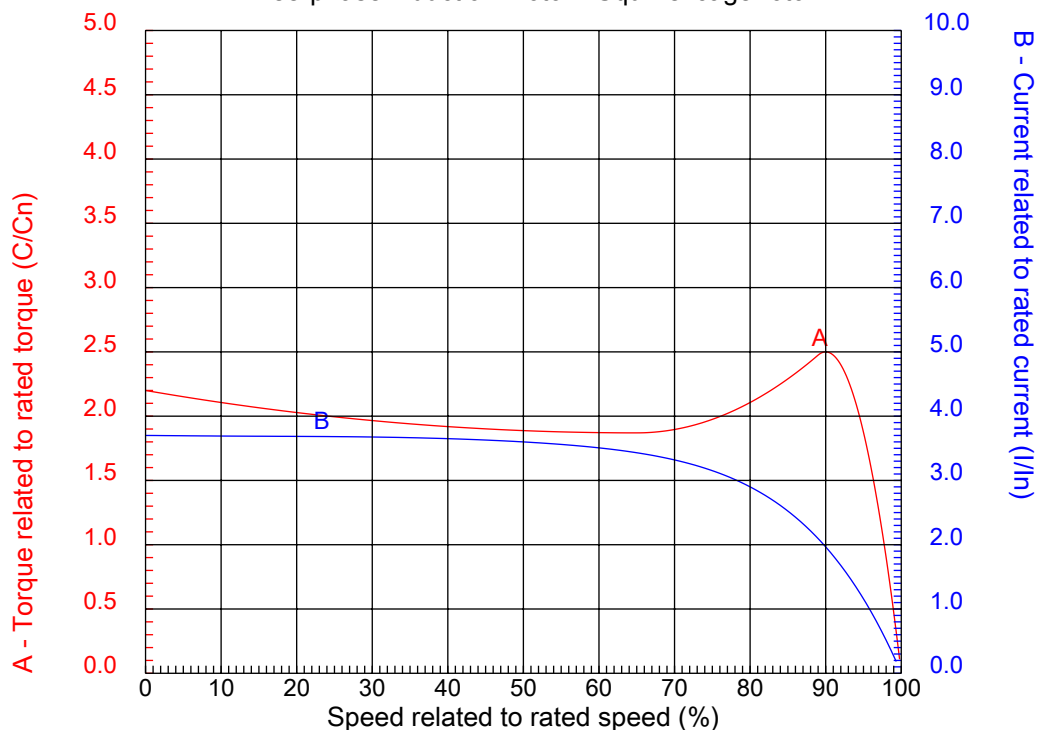

Customer :
Product line : Cooling Tower Motors : High Efficiency - Two Speed

Frame	: 256T	Locked rotor current (I _l /I _n)	: 3.7
Output	: 2.5 HP	Duty cycle	: S1
Frequency	: 60 Hz	Service factor	: 1.15
Full load speed	: 880	Design	: A
Voltage	: 200 V	Locked rotor torque	: 220 %
Rated current	: 15.0 A	Breakdown torque	: 250 %
Insulation class	: F		

Notes:

Performed by

Checked

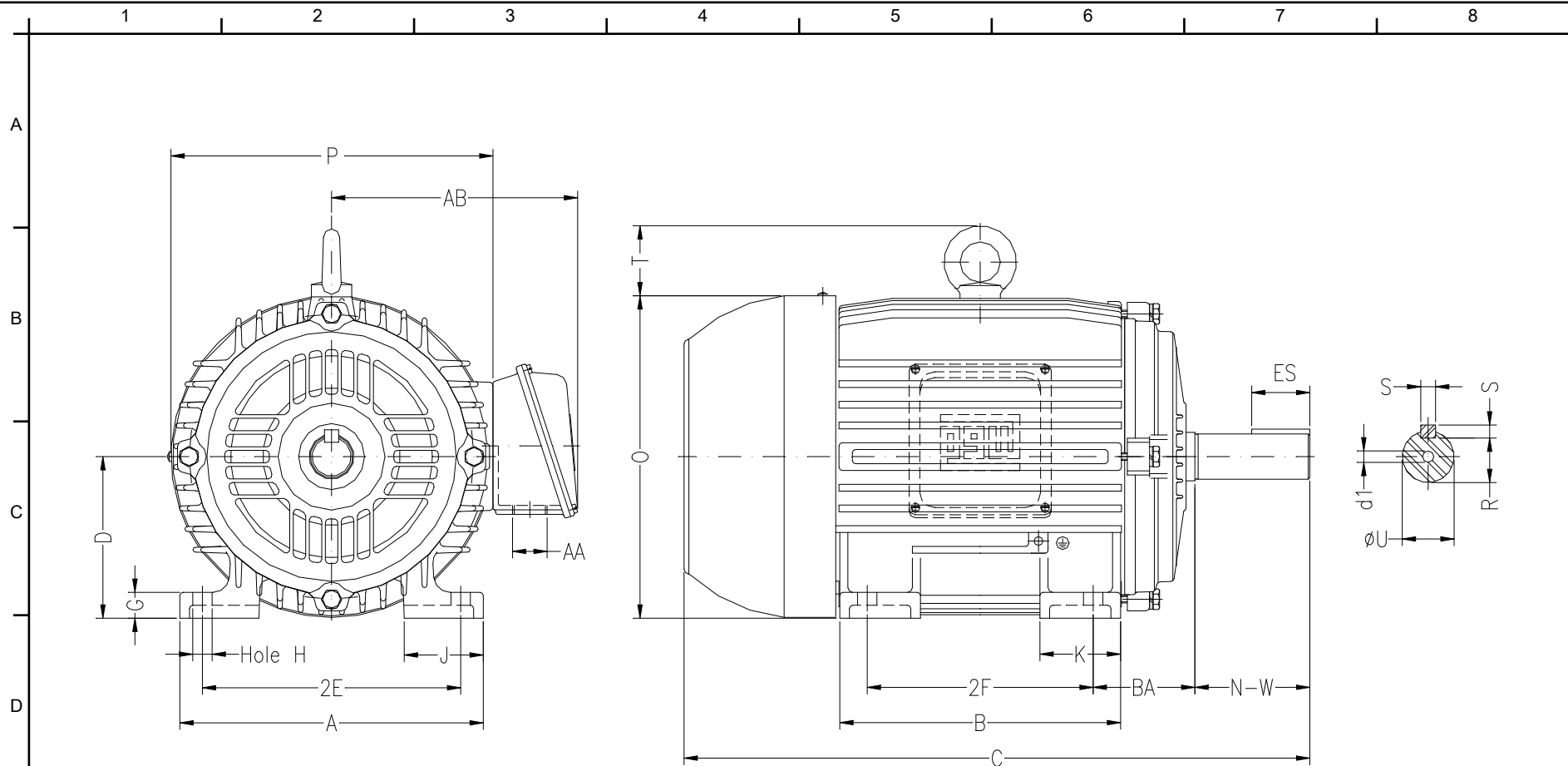

Notes:

Performed by:

Checked:

Customer:

Cooling Tower Motors : High Efficiency - Two Speed

Three-phase induction motor
Frame 256T - IP55

31-DEC-2012



2E 10.000	2F 10.000	H 0.531	BA 4.250	A 12.126
B 11.732	C 24.945	D 6.250	G 0.817	J 2.520
K 2.559	O 12.431	P 12.283	ES 2.756	S 0.375
N-W 4.000	U 1.625	R 1.406	AB 10.079	AA NPT 1 1/2"
d1 A 4	Flange FD-317	AJ 12.500	AK 11.000	BD 14.000
BF 0.828	BB 0.203			