



No.:

Date: 31-DEC-2012

Customer :

TECHNICAL PROPOSAL

Three-phase induction motor - Squirrel cage rotor

Product line : Cooling Tower Motors : High Efficiency - Two Speed

Catalog Number : 05089EP3QCT365V2

List Price : \$11,093

Notes:

Performed by:

Checked:



No.:

Date: 31-DEC-2012

DATA SHEET

Three-phase induction motor - Squirrel cage rotor

Customer :
Product line : Cooling Tower Motors : High Efficiency - Two Speed

Frame : 364/5T
Output : 12.5 HP
Frequency : 60 Hz
Poles : 8
Full load speed : 885
Slip : 1.67 %
Voltage : 230 V
Rated current : 42.4 A
Locked rotor current : 212 A
Locked rotor current (I_L/I_n) : 5.0
No-load current : 29.0 A
Full load torque : 73.2 lb.ft
Locked rotor torque : 250 %
Breakdown torque : 250 %
Design : A
Insulation class : F
Temperature rise : 80 K
Locked rotor time : 11 s (hot)
Service factor : 1.15
Duty cycle : S1
Ambient temperature : -20°C - +40°C
Altitude : 1000
Degree of Protection : IP55
Approximate weight : 988 lb
Moment of inertia : 23.251 sq.ft.lb
Noise level : 62 dB(A)

	D.E.	N.D.E.	Load	Power factor	Efficiency (%)
Bearings	6314 C3	6314 C3	100%	0.66	82.5
Regreasing interval	9789 h	9789 h	75%	0.58	81.5
Grease amount	27 g	27 g	50%	0.46	78.5

Notes:

Performed by

Checked



No.:

Date: 31-DEC-2012

PERFORMANCE CURVES RELATED TO RATED OUTPUT Three-phase induction motor - Squirrel cage rotor

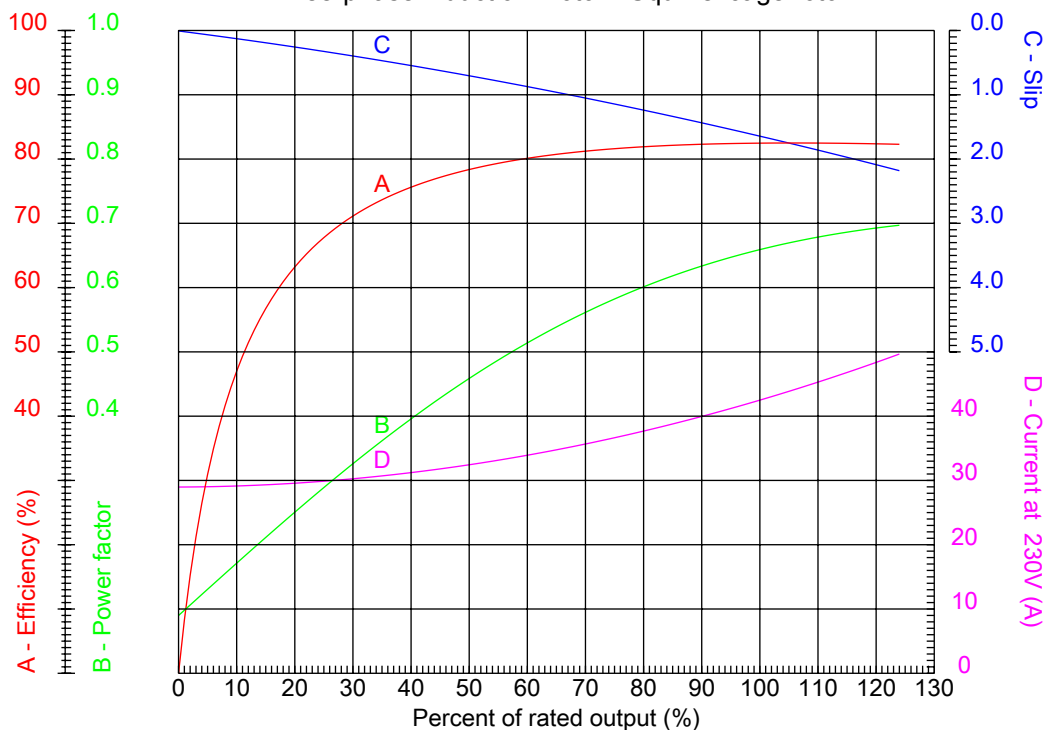

Customer :
Product line : Cooling Tower Motors : High Efficiency - Two Speed

Frame	: 364/5T	Locked rotor current (I _l /I _n)	: 5.0
Output	: 12.5 HP	Duty cycle	: S1
Frequency	: 60 Hz	Service factor	: 1.15
Full load speed	: 885	Design	: A
Voltage	: 230 V	Locked rotor torque	: 250 %
Rated current	: 42.4 A	Breakdown torque	: 250 %
Insulation class	: F		

Notes:

Performed by

Checked



No.:

Date: 31-DEC-2012

CHARACTERISTIC CURVES RELATED TO SPEED

Three-phase induction motor - Squirrel cage rotor

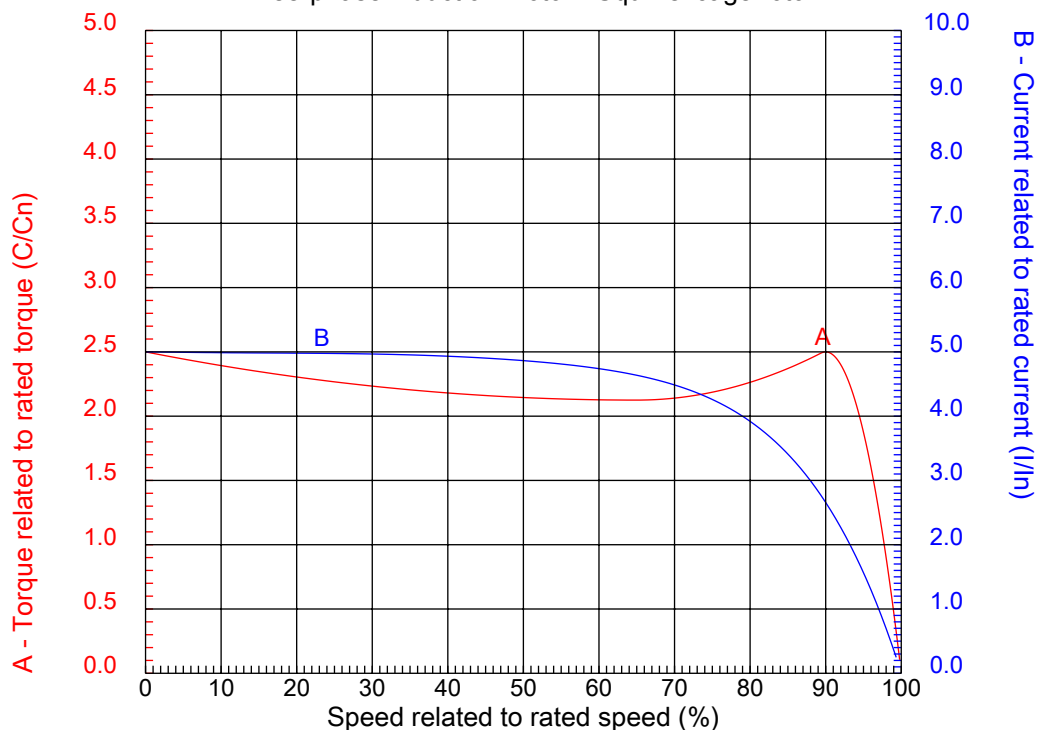

Customer :
Product line : Cooling Tower Motors : High Efficiency - Two Speed

Frame	: 364/5T	Locked rotor current (I _l /I _n)	: 5.0
Output	: 12.5 HP	Duty cycle	: S1
Frequency	: 60 Hz	Service factor	: 1.15
Full load speed	: 885	Design	: A
Voltage	: 230 V	Locked rotor torque	: 250 %
Rated current	: 42.4 A	Breakdown torque	: 250 %
Insulation class	: F		

Notes:

Performed by

Checked

1 2 3 4 5 6 7 8

A
B
C
D
E
F

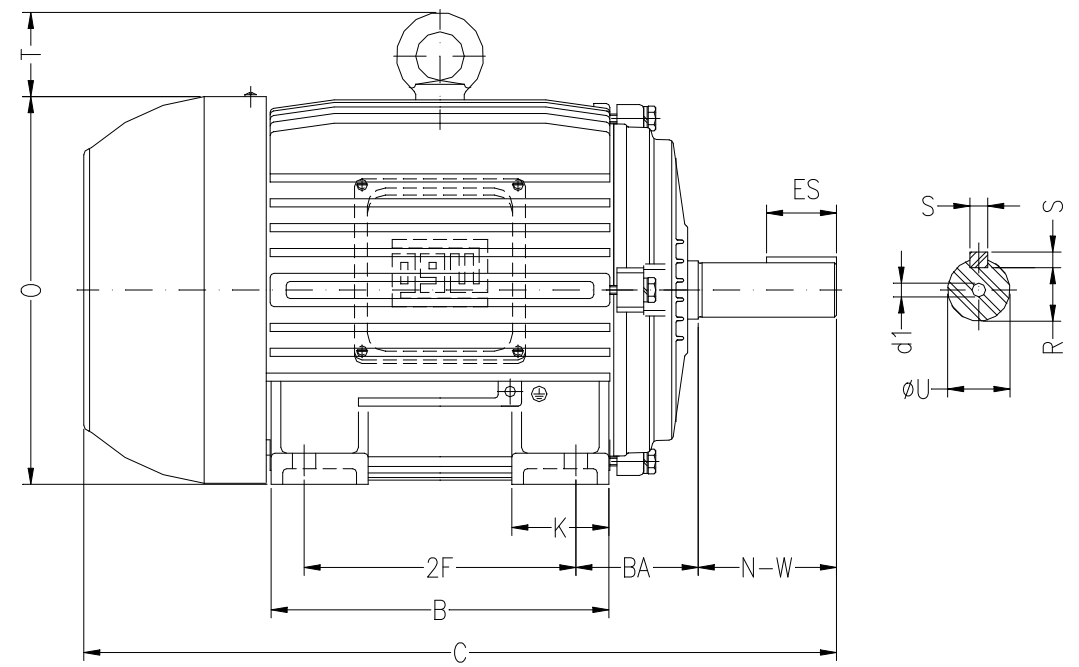
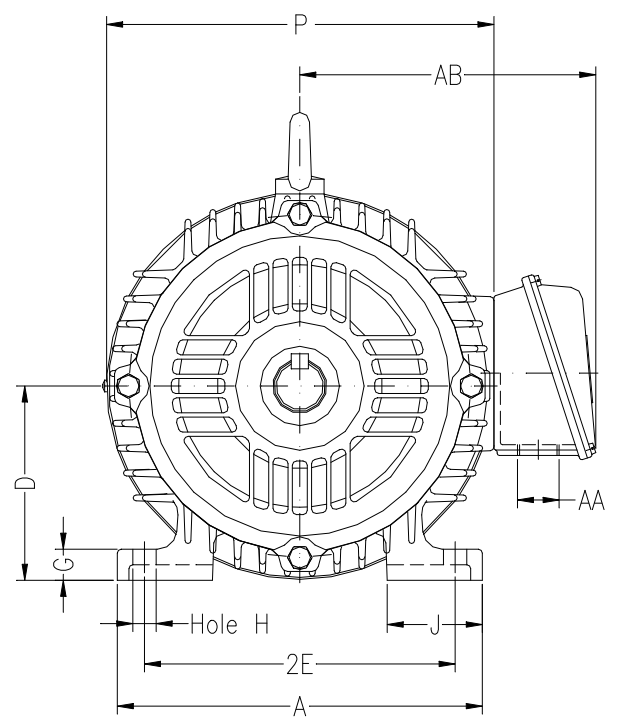

Notes:

Performed by:

Checked:

Customer:

Cooling Tower Motors : High Efficiency - Two Speed

Three-phase induction motor
Frame 364/5T - IP55

31-DEC-2012



2E 14.016	2F 11.260/12.244	H 0.657	BA 5.875	A 17.165
B 15.394	C 33.709	D 9.000	G 1.480	J 3.150
K 4.134	O 18.502	P 18.740	ES 4.330	S 0.625
N-W 5.874	U 2.375	R 2.019	AB 16.380	AA NPT 3"
d1 DUNC 3/4"-10	Flange FD-406	AJ 16.000	AK 14.000	BD 17.716
BF 0.828	BB 0.203			