





# Safgard™

711 Series

## Low Water Cut-Off Feeder Combination for Steam Boilers

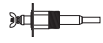
120 VAC Operating Voltage

-  No moving parts in water. No floats to hang-up or foul.
-  Unique two probe design. Bouncing water line won't cause on-off burner cycling or water valve slamming noise.
-  Easy installation. Quick hook-up fittings adapt control to all 8" to 14" sight glasses.
-  Simple fast wiring. Can be used with any standard automatic water feeder.



**WARNING:** Power must be off during installation or servicing of the control. Only qualified personnel may install or service the control in accordance with local codes and ordinances. Read instructions completely before proceeding. Caution – Disconnect power supply before beginning installation to prevent electrical shock or equipment damage.

### HOW TO INSTALL

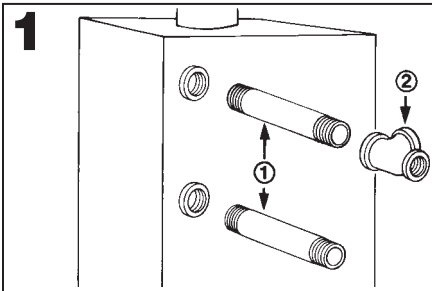

Remove gauge glass assembly and nipples replacing nipples with two 6" brass nipples provided ①. Install 1/2" x 1/2" x 3/8" tee ② on top nipple.

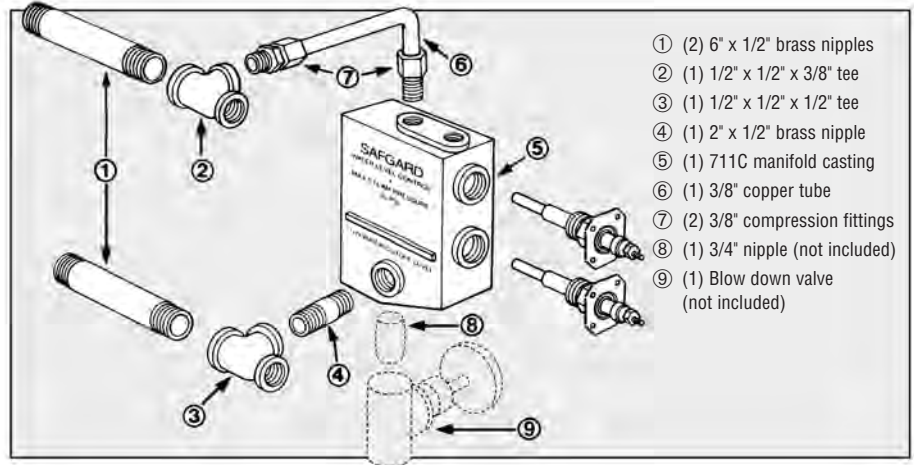

- ① (2) 6" x 1/2" brass nipples
- ② (1) 1/2" x 1/2" x 3/8" tee
- ③ (1) 1/2" x 1/2" x 1/2" tee
- ④ (1) 2" x 1/2" brass nipple
- ⑤ (1) 711C manifold casting
- ⑥ (1) 3/8" copper tube
- ⑦ (2) 3/8" compression fittings
- ⑧ (1) 3/4" nipple (not included)
- ⑨ (1) Blow down valve (not included)

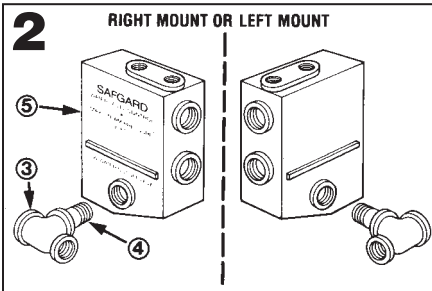

Install 1/2" x 2" brass nipple ④ and 1/2" x 1/2" x 1/2" tee ③ to 1/2" threaded hole in casting ⑤. Note: Casting is designed for either left or right mounting on gauge glass. Be sure to plug hole on opposite side.

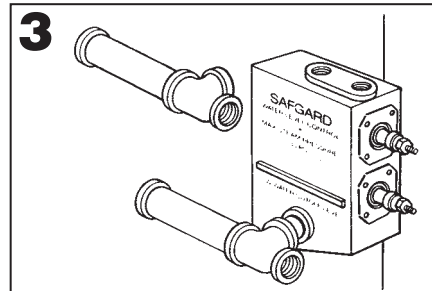

Thread tee attached to casting into bottom 6" nipple. Tighten until casting is vertical.

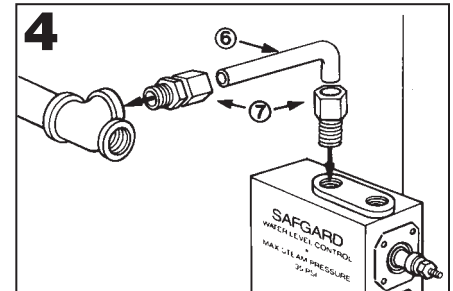

Install compression fittings ⑦ into casting and top tee. Size copper tubing ⑥ and tighten between the two compression fittings.

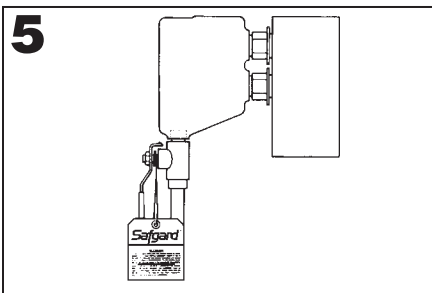

Attach control to probes using No. 8-32 self tapping screws provided. Install blow down valve (by others) in bottom 3/4" tapped hole. Be sure to attach maintenance tag in prominent place near valve.

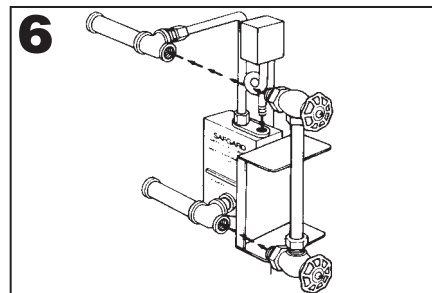

Reattach gauge glass cocks and gauge glass into end of 1/2" tees. Pressure-trol can be threaded into 1/8" threaded hole on top of casting. If pressure-trol is not used, plug 1/8" hole on top of casting.

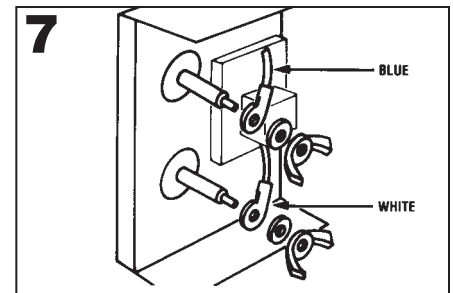

Attach blue probe lead wire to upper probe and white probe lead wire to bottom probe with wing nuts and lock washers provided.

**HYDROLEVEL COMPANY**

83 Water Street • New Haven, CT 06511 • Phone (203) 776-0473 • FAX (203) 773-1019 • [www.hydrolevel.com](http://www.hydrolevel.com)

## WIRING METHOD A: SAME POWER SOURCE FOR CONTROL AND BURNER CIRCUIT.

**A1**

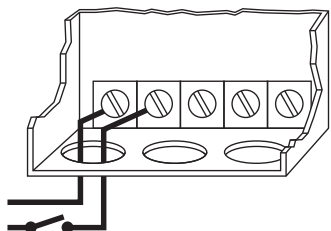

◀ **A1** Connect input voltage (120 VAC, 60HZ) to terminals G and H. 120 VAC, 60HZ must be supplied to terminals G and H for internal operation of the control.

Install a jumper between terminal H and terminal P(1). Power from terminal P(1) is supplied to terminal P(2) when water reaches the upper probe. Power to terminal P(2) is removed when water falls below the bottom probe.

**A2** ▶

**A2**

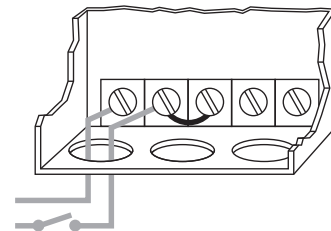

**A3**

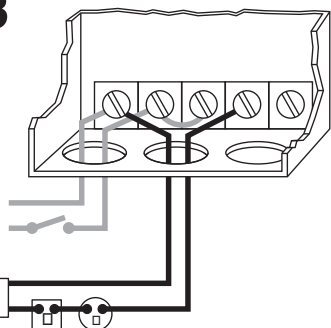

◀ **A3** Connect terminal G to burner circuit neutral. Connect terminal P(2) to burner circuit in series with other limit controls. Consult boiler manufacturer's instructions for proper terminal connections. NOTE: Control is wired in series with and before other limits.

Feeder Connection: Connect feeder common to terminal G. Connect feeder hot to terminal V. Whenever water falls below the lower probe, power is supplied to the feeder terminal V. When water reaches the upper probe, power to the feeder is removed.

**A4** ▶

**A4**

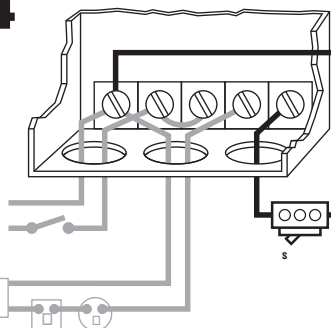

## WIRING METHOD B: SEPARATE POWER SOURCE FOR CONTROL AND BURNER CIRCUIT.

**B1**

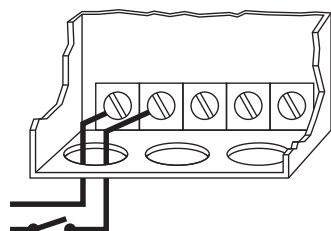

◀ **B1** Connect input voltage (120 VAC, 60HZ) to terminals G and H. 120 VAC, 60HZ must be supplied to terminals G and H for internal operation of the control.

Connect hot lead from burner control circuit to terminal P(1). This terminal supplies power to terminal P(2) in normal operating conditions when water is at the probe. Connect neutral to burner circuit. NOTE: Consult boiler manufacturer's instructions for proper terminal connections.

**B2** ▶

**B2**

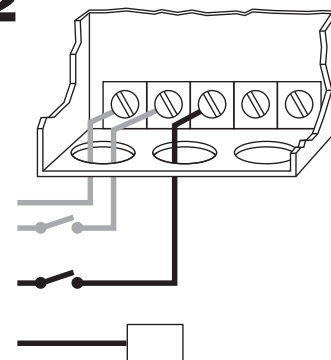

**B3**

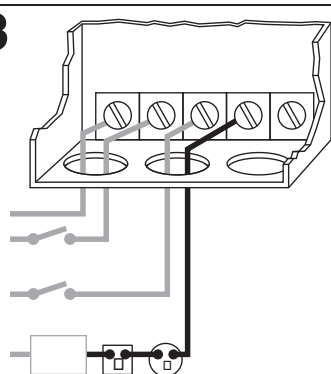

◀ **B3** Connect terminal P(2) to burner circuit in series with other limit controls. Consult boiler manufacturer's instructions for proper terminal connections. NOTE: Control is wired in series with and before other limits.

Feeder Connection: Connect feeder common to terminal G. Connect feeder hot to terminal V. Whenever water falls below the lower probe, power is supplied to the feeder terminal V. When water reaches the upper probe, power to the feeder is removed.

**B4** ▶

**B4**

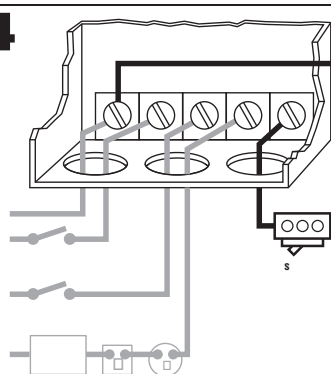

**NOTE:** All schematic diagrams show all systems in the off position. No power applied.

## PRINCIPLE OF OPERATION

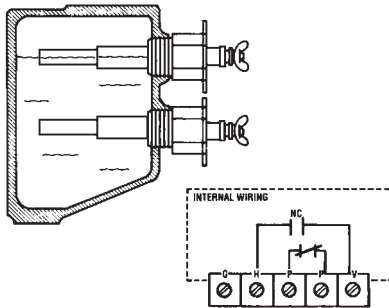

Hydrolevel controls are electronically operated. Water is used as an electrical conductor to complete a circuit from the probe to the control unit. The control unit provides switching contacts to operate the burner circuit and optional water feeder.

The 711 Series low water cut-off is designed to maintain a safe operating water level in the boiler. When water is in contact with the upper probe, the control enables the burner to fire (switch contacts P – P are closed). When the water level falls below the lower probe, the control will de-energize the burner circuit. The control will not re-energize the burner until the water level is restored to the upper probe level.

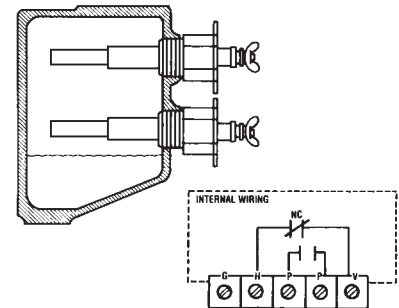

The 711WF includes a feed valve designed to automatically restore the water level in the event of a low water condition. When water falls below the lower probe, the 711 will energize the feed valve (switch contact H – V make). When the boiler

water level is restored to the upper probe, the 711 will de-energize the feed valve and restore burner operation. The 711CF does not include a feed valve, but does provide contacts for operation of a steam boiler water feeder.

## INSTALLATION & OPERATION OF FEEDER

A feed valve is supplied standard with control model 711WF. It is recommended that a shut-off valve and union be installed on either side of the water feed valve and a by-pass valve and piping be installed to permit removal of the water feed valve should service be required. During normal operation, by-pass valve should be closed and isolation valves should remain open.

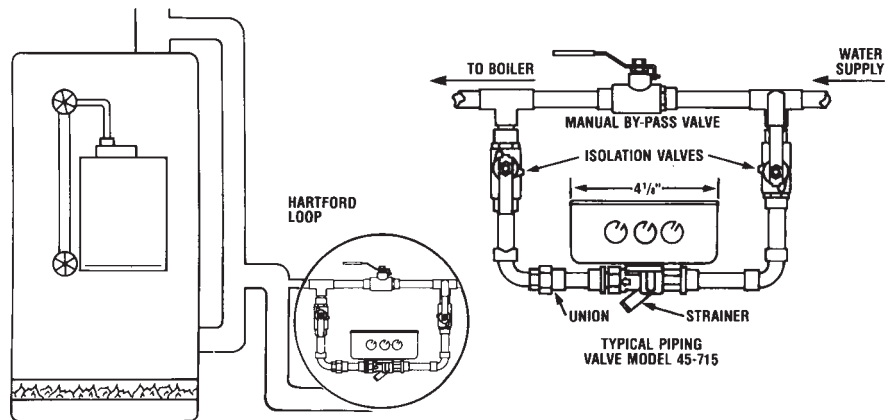

## OPERATING INSTRUCTIONS

**NOTE:** Hydrolevel recommends that the boiler manufacturer's procedures for skimming the boiler be performed prior to placing the control into operation.

- 1 After installation, raise the boiler water level until water is in contact with the upper probe. Turn on power and set the thermostat to call for heat. The burner should fire immediately.
- 2 Using the boiler drain, slowly lower the water level to a point below the lower probe. The burner should shut down immediately upon a low water condition.

**NOTE:** The water should not be lowered beyond a visible point on the gauge glass.

**IMPORTANT:** If the burner does not shut down in a low water condition, turn off power immediately and refer to troubleshooting instructions below.

## TROUBLESHOOTING

- 1 If the burner does not shut down upon water falling below the lower probe: Remove power to the burner and check installation. Check wiring and make sure that burner is connected to the fourth terminal from left on terminal (P2). If wiring is correct, check to make sure the probes are not falsely grounded. Voltage between the probes and chassis ground should

be 120-140 VAC with water beneath both probes. A lower reading may indicate a shorted probe. Remove probes and check for contamination.

- 2 If the burner will not fire with water at the top probe: With a voltmeter and power applied at terminals G and H: Check the voltage between

the upper probe and chassis ground. Reading should be 0-10 VAC with water at the upper probe. A higher reading may be the result of poorly conductive water or probe contamination. Remove probes and check for contamination. If the burner will still not fire after cleaning probes, contact factory for assistance.

## MAINTENANCE

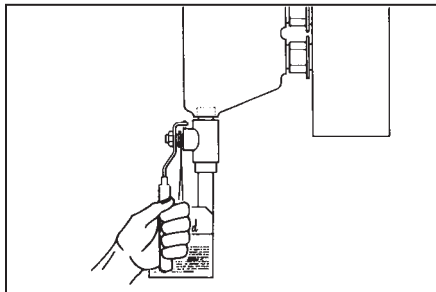

To insure proper operation, the 711 Series Control requires periodic maintenance. During normal boiler operation, sediment may accumulate in the probe housing. If left unchecked, this sediment can build up and interfere with the operation of the control. Failure to properly maintain the control can lead to severe damage to the boiler or other property, personal injury or death.

To flush the sediment from the chamber, the control must be blown down throughout the heating

season in accordance with the following schedule:

First Week Following Installation: Every Day.  
Thereafter: Once a Week.

**Instructions:** To blow down the control, place a heat resistant pail directly beneath the control casting blow down valve. Open the valve and allow the sediment and water to drain into the pail. Continue to drain the water until it runs clean. One to two gallons is generally sufficient.

**CAUTION:** Protect yourself when blowing down the control. Hot water and steam will flow out of the control during this process.

## DIMENSIONS

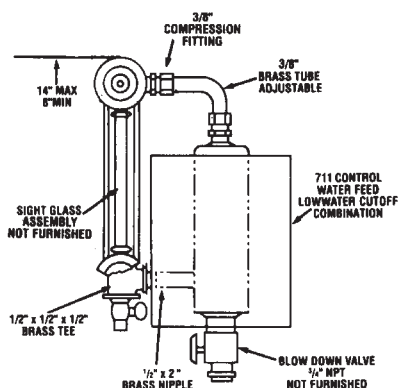

FRONT VIEW

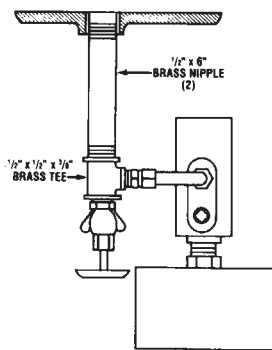

TOP VIEW

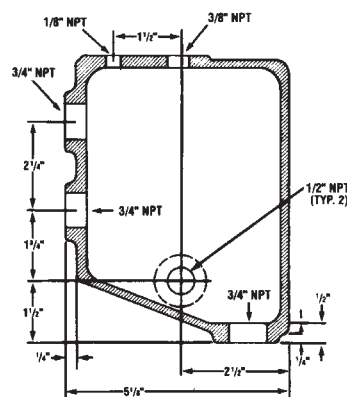

CASTING

## SPECIFICATIONS

**MAXIMUM PRESSURE:** 35 PSI  
**INPUT VOLTAGE:** 120 VAC, 60 HZ  
**SWITCH RATINGS:** 5.8 FLA, 34.8 LRA  
**SWITCH CONTACTS:** SPDT  
**ALARM CIRCUIT:** 125 VA @ 120 VAC Pilot Duty



## OPTIONS

The VXT water feeder (available separately) can be used with Hydrolevel or other low water cut-offs to automatically replenish boiler water in the event of a low water condition. The VXT offers programmable feed amount and feed delay settings. These can easily be set to ensure the proper feed amount and to provide adequate time for condensate to return to the boiler before starting a feed cycle. The VXT's digital feed counter tracks the amount of water added to the boiler exposing sys-

tem leaks, which can significantly shorten the life of a cast iron boiler. Additional features including a manual feed button under-feed and flood protection, make the VXT an ideal choice for safety and convenience.



## LIMITED MANUFACTURER'S WARRANTY

We warrant products manufactured by Hydrolevel Company to be free from defects in material and workmanship for a period of two years from the date of manufacture or one year from the date of installation, whichever occurs first. In the event of any claim under this warranty or otherwise with respect to our products which is made within such period, we will, at our option, repair or replace such products or refund the purchase price paid to us by you for such products. In no event shall

Hydrolevel Company be liable for any other loss or damage, whether direct, indirect, incidental or consequential. This warranty is your EXCLUSIVE remedy and shall be IN PLACE OF any other warranty or guarantee, express or implied, including, without limitation, any warranty of MERCHANTABILITY or fitness for a particular purpose. This warranty may not be assigned or transferred and any unauthorized transfer or assignment thereof shall be void and of no force or effect.

**HYDROLEVEL  
COMPANY**

83 Water Street • New Haven, CT 06511 • Phone (203) 776-0473 • FAX (203) 773-1019 • [www.hydrolevel.com](http://www.hydrolevel.com)