

ENG. NO. 73000-K
 PAT. NO. 5,203,496.
 5,323,960.
 6,637,668.
 7,140,394.

Thermostatic Water Controller Model 802 High-Low Water Mixer Unit No. 73000

ASSE 1017 Approved



Certified to
 CSA B125.3

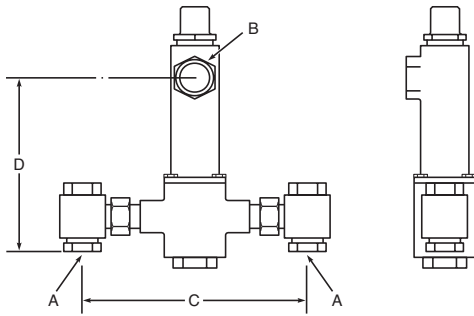

Master water mixing valve shall be of the thermostatic type with liquid-filled thermal motor. It shall have bronze body construction with replaceable corrosion-resistant components. Valve construction shall employ a sliding piston control mechanism. Sliding piston and liner shall be of stainless steel material. Valve shall come equipped with union end stop and check inlets with removable stainless steel strainers. Valve shall control temperature from a low flow of 2 GPM* up to a maximum flow rate for a given pressure differential. Valve shall provide protection against hot or cold supply line failure and thermostat failure.

DIMENSIONS:

Valve Number	A N.P.T.	B N.P.T.	C	D
802	1"	1 1/4"	11"	12"

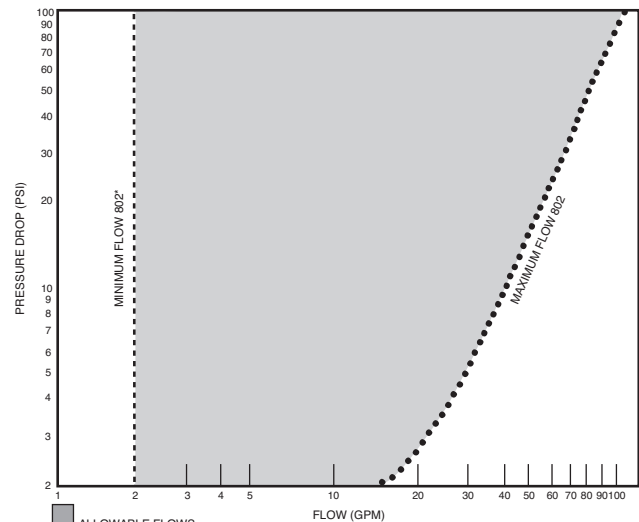

FINISH: Bronze
 Chrome
 Other

TEMP. RANGE	SET POINT	
70° to 100°F	80°F	<input type="checkbox"/>
90° to 120°F	110°F	<input type="checkbox"/>
110° to 140°F	130°F	<input type="checkbox"/>
Special _____	_____	<input type="checkbox"/>

Optional Test Connection
 Including garden hose connection, shut-off and thermometer.

Bronze
 Chrome

CAPACITIES - MODEL 802

Pressure Drop PSI	5	10	20	30	45	60	80
Valve Number	Capacity						
802-GPM	28	39	54	66	80	91	103
802-LPM	106	148	208	247	303	341	388

*1/2 gpm when properly installed in recirculated system.



MANUFACTURING CO., INC.

5330 East 25th Street
 Indianapolis, Indiana 46218
 Phone (317) 261-1212
 Fax (317) 261-1208

Design and specification subject to change without notice.