

ENG. NO. 73100-H  
 PAT. NO. 5,203,496.  
 5,323,960.  
 6,637,668.  
 7,140,394.

# Thermostatic Water Controller Model 805<sup>®</sup> High-Low Water Mixer Unit No. 73100

**ASSE** ASSE 1017 Approved



**Certified to  
 CSA B125.3**

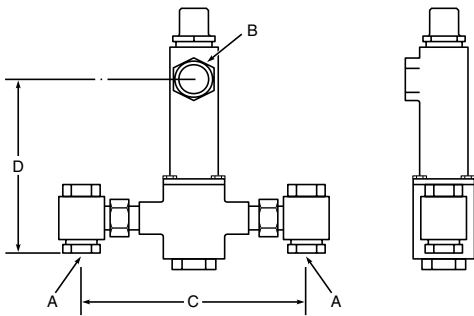

Master water mixing control valve shall be of the thermostatic type with liquid-filled motor. It shall have bronze body construction with replaceable corrosion-resistant components. Valve construction shall employ sliding piston control mechanism. Piston and liner shall be of stainless steel material. Valve shall come equipped with removable union end stop and check inlets with stainless steel strainers. Valve shall control temperature from a low flow of 5 GPM\* up to a maximum flow rate for a given pressure differential. Valve shall provide protection against hot or cold supply line failure and thermostat failure.

**DIMENSIONS:**

Valve Number	A N.P.T.	B N.P.T.	C	D
805	2"	2"	15"	13 1/2"

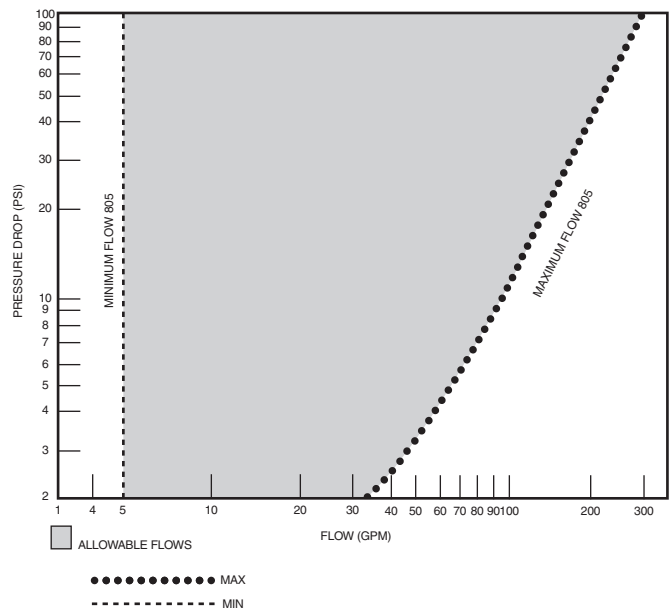

**FINISH:** Bronze   
 Chrome   
 Other

**TEMP. RANGE**      **SET POINT**

70° to 100°F      80°F   
 90° to 120°F      110°F   
 110° to 140°F      130°F

Special \_\_\_\_\_

**Optional Test Connection**   
 Including garden hose connection, shut-off and thermometer.

Bronze   
 Chrome

**CAPACITIES - MODEL 805**

Pressure Drop PSI	5	10	20	30	45	60	80
<b>Valve Number</b>	<b>Capacity</b>						
<b>805-GPM</b>	64	96	133	165	200	230	265
<b>805-LPM</b>	242	363	503	624	757	870	1003

\*1/2 gpm when properly installed in recirculated system.



**MANUFACTURING CO., INC.**

5330 East 25th Street  
 Indianapolis, Indiana 46218  
 Phone (317) 261-1212  
 Fax (317) 261-1208

Design and specification subject to change without notice.