



TRANSFORMING TECHNOLOGIES, LLC
OUTSTANDING ALTERNATIVES IN STATIC CONTROL

Ptec™ Static Eliminators

Airflex Ionizing Nozzle

Model IN4000



Instruction Manual

Contents

1	Description	
	Model IN4000	1
	About <i>Plec™</i> Technology	1
	Features	1
	Power Requirements	2
2	Operation and Use	
	Environmental Conditions	2
	Set-up and Placement	2
	Mounting	3
	Power and Gas Connection	3
3	Maintenance	
	Periodic Maintenance	4
	Cleaning Exterior	4
	Cleaning Emitter Points	4
	Emitter Point Replacement	5
	Service	6
	Troubleshooting	6
4	Specifications	7
5	Service and Warranty	8
6	IN4000 Line Drawing	9

Description

Ionizing Air Nozzle Model IN4000

The IN4000 Airflex ionizer combines exceptionally fast static decay capability with excellent balance stability, all in a small footprint. Designed to protect most static sensitive devices, the IN4000 uses a specialized piezoceramic **technology that makes all the Ptec™ ionizers so reliable.**

The height and angle of the nozzle can be easily adjusted with a metal snake shape tube ,which is very convenient to operate. The main unit of the device is equipped with a small HV power unit. No external HV power unit and HV wiring is needed.

About Ptec™ Technology

A specialized piezoelectric high voltage transformer **makes Ptec™ ionizers among the most reliable products available. Ptec™ ionizers are designed to remain in balance** and to alarm when the HV output affects performance. The model IN4000 ionizing air nozzle produces a 68KHz AC output of approximately 2200V and a **continuous stream of balanced air ions. Ionizers that use Ptec™** technology do not require calibration and only minimal maintenance.

Features

The IN4000 features the inherently stable output of all **Ptec™ ionizers and high frequency AC (68KHz) ion emission.** The flexible metal neck, with multiple nozzle options allows for easy operation and service of emitters. A foot switch and .01 micron filter combine to deliver clean air at the correct pressure when needed.

Features cont'd.

- Small ,light design in shape. No extra power unit is needed.
- The device incorporates with an ultra-small HV power unit. It has no HV wiring, so it is safe and convenient to operate.
- The height and angle of the nozzle can be easily adjusted.
- The foot switch can control both electric power and air supply.
- It is equipped with an ionization indicator light (green) and an abnormal HV indicator light (red).
- The device is equipped with auto ion balance. Within 10V
- Special alloy discharge needle, more durable than tungsten ones.

Power Requirements

The main unit of the device is equipped with a small HV power unit. No external HV power unit and HV wiring is needed.

Operation and Use

The IN4000 can be operated in areas where humidity is 20-70% RH (Non-condensing). Excess humidity may affect ionizer performance. The temperature range for the IN4000 is **65-78°F (18-25°C)**.

Set-up and Placement

Use the IN4000 ionizing air nozzle in immediate proximity to a static sensitive area or object.

<p>Caution</p> 	<p>Do not use this ionizer in an explosive environment! Corona ionizers produce a weak plasma that can cause ignition in explosive environments.</p>
--	--

Power and Gas Connection

- Connect the foot switch to the base of the ionizer.
- Attach the IN4000 to the gas line using the appropriate **tubing. The IN4000 comes with a 1/4" quick release connector.** Adjust pressure as required.
- Connect the power cord to its corresponding inlet on the base of the ionizer.
- Make certain the unit is grounded.
- **Turn the unit on with the red "On - OFF" button.**

Operation

- Press the foot switch to creates a stream of positive and negative air ions.
- **A green light labeled "Power" will illuminate to signal the IN4000 is operating.**

<p>Caution</p> 	<p>The IN4000 operates only with clean dry air (CDA) or nitrogen (N2). Operator must provide clean and filtered incoming gas to remove moisture, oil and particles from the source supply.</p>
--	--

- The ionized airflow is directed through the nozzle. The metal neck of the ionizer can be bended to direct the flow toward Work area.
- Turn the power switch off after operation.

<p>Caution</p> 	<p>The IN4000 is not designed to withstand high air pressure. The product should be installed with shutoff valve upstream. The output side of the nozzle should always be at atmospheric pressure.</p>
--	--

Alarm

The device is equipped with abnormal HV alarm. The red alarm indicator light illuminates when the following situations occur:

1. Low output HV
2. Short circuit
3. Abnormal HV discharge
4. Wet air flow
5. Frequent turning on and off of the photoelectric switch in a short time.

Caution !	The only serviceable parts inside the ionizer are the replaceable emitter points. Any unauthorized service will void the warranty and may result in additional repair fees.
--------------------------------	---

Ionization Performance

The ionization performance is tested according to American EOS/ESD-STM3.1-2000 standard.

References are as follows:

Air pressure(kgf / cm ²)	45	55	70	85
Positive decay time (sec)	0.5	0.4	0.3	0.2
Negative decay time(sec)	0.5	0.4	0.3	0.2
Ion balance(V)	Less than 0±30V			

Note: The test results will vary slightly due to different test conditions.

Periodic Maintenance

The only regular maintenance required for the IN4000 is the periodic cleaning of the emitter point. Emitter point cleaning affects the static decay ability of the ionizer and is important for maintaining its optimal performance.

Cleaning the emitter points

Contaminants will gradually accumulate on the tip of the emitter points with continuous use. Periodic cleaning of the emitter points is necessary to maintain the performance of the ionizer. If the emitter points are dirty, clean them with a polyester or cotton swab and IPA. Do not damage or loosen the emitter points.

Follow these instructions to clean the emitter points:

1. Remove the output nozzle (threaded).
2. Moisten a swab in the IPA solution and wipe the emitter point until it is free of particles.
3. Make certain the emitter point is straight and undamaged.
4. Replace the output nozzle.
5. Make sure the emitter points are dry before turning on the power

Emitter Point Replacement

The IN4000 uses tungsten alloy precision etched emitter needles. Contact Transforming Technologies for information about ordering replacement emitters. The part number for emitters is listed below:

<u>Replacement part</u>	<u>Part Number</u>
IN4000 tungsten replacement emitters	22-3423

Because the IN4000 high voltage output is AC, emitter erosion from the ionization process on the electrodes is minimal. Unless physically broken or stressed, the IN4000 emitters should last the life of the ionizer.

Follow these instructions to remove the emitter points:

1. Turn off and disconnect the unit from the AC power.
2. Remove the output nozzle.
3. Unscrew the emitter point using needle nose pliers.
4. Replace and tighten the new emitter using the same tool. Do not over-tighten.
5. Make certain the emitter points are straight and undamaged.
6. Replace the output nozzle.

Service

Ptec™ ionizers are reliable products with a long service life. If you feel your unit is not operating properly, turn off the unit and disconnect the power cord. Contact Transforming Technologies' Technical Support for repair assistance.

Troubleshooting

The information below provides a reference for problems that may arise with your IN4000 ionizing air nozzle. If you have other problems not covered below, please contact **Transforming Technologies' Technical Support for repair assistance**

<u>Problem</u>	<u>Causes</u>
<ul style="list-style-type: none">• Balance outside specifications.• Alarm light activated	Emitter points are dirty, damaged or not straight. Clean or replace Low HV output, call for repair Unit is arcing, call for repair Short circuit, call for repair

Specifications

Power supply volt	AC 100V~240V 50/60Hz
Output HV	AC2200V
Safety Performance	Abnormal HV Alarm
Tempreture Range	0~40°C
Air Pressure Range	28-100 (psi)
Ozone Density	Less than 0.01ppm
Ion Balance	0±30V
Indicators	ON/OFF: red LED, POWER: green LED
Controls	On/Off button
Certifications	

<h2>Caution</h2> !	When adjusting the angle the IN4000 nozzle, grip the metal snake neck only. DO NOT grip the plastic nozzle. Using the plastic nozzle to adjust angle may cause physical or internal damage.
------------------------------	---



Service and Warranty

Transforming Technologies, LLC provides a limited warranty for the Model IN4000 ionizing air nozzle. All new products are guaranteed to be free from defects in material and workmanship for a period of one (1) year from the date of shipment. Liability is limited to servicing (after evaluating, repairing or replacing) any product returned to Transforming Technologies. The company does not warrant damage due to misuse, neglect, alteration or accident. In no event shall Transforming Technologies be liable for collateral or consequential damages.

To receive service under warranty, please contact Transforming Technologies Technical Support.

About Transforming Technologies

Since 1998, Transforming Technologies has helped electronic manufacturing facilities to protect their products and processes from the many serious problems associated with static electricity.

Transforming Technologies offers a wide range of unique and outstanding products to detect, protect, eliminate and monitor electrostatic charges. Our products are integral components of an effective static control program.

IN4000 Line Drawing

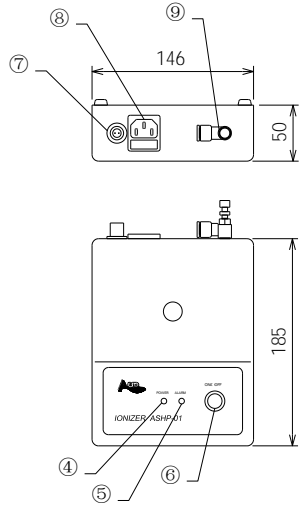
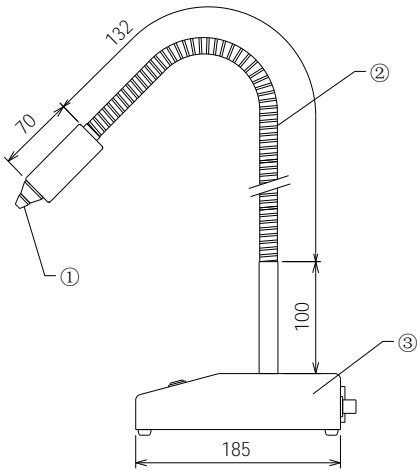

- ① Nozzle
- ② Snake shape tube
- ③ Base
- ④ LED (Green)
- ⑤ Alarming LED (Red)
- ⑥ Power switch
- ⑦ Foot switch outlet
- ⑧ Power cord outlet (Including fuse)

TRANSFORMING TECHNOLOGIES, LLC



3719 King Rd.
Toledo, Ohio 43617

Phone: 419-841-9552

Fax: 419-841-3241

E-mail: info@transforming-technologies.com