

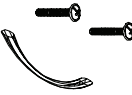





TUN005MH	TUN001FC	TUN002AB	TUN027SC		TUN013LB	TUN018SC	
<b>A</b>  96mm Metal Scallop Shape Handle 2 Sets	<b>B</b>  File Clip 2 Pcs	<b>C</b>  300 x 16 x 3mm Metal Bar 1 Pc	<b>D</b>  Screw M6 x 40mm Washers Dia. 17mm 4 Sets	<b>E</b>  Keys 1 Set	<b>F</b>  6 Hole L-Bracket 2 Pcs	<b>G</b>  Screw #4 x 5/8" 20 Pcs + 2 Extra Pcs	<b>H</b>  8 Hole L-Bracket 1 Pc

### STEP 1



### STEP 2

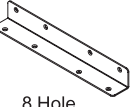
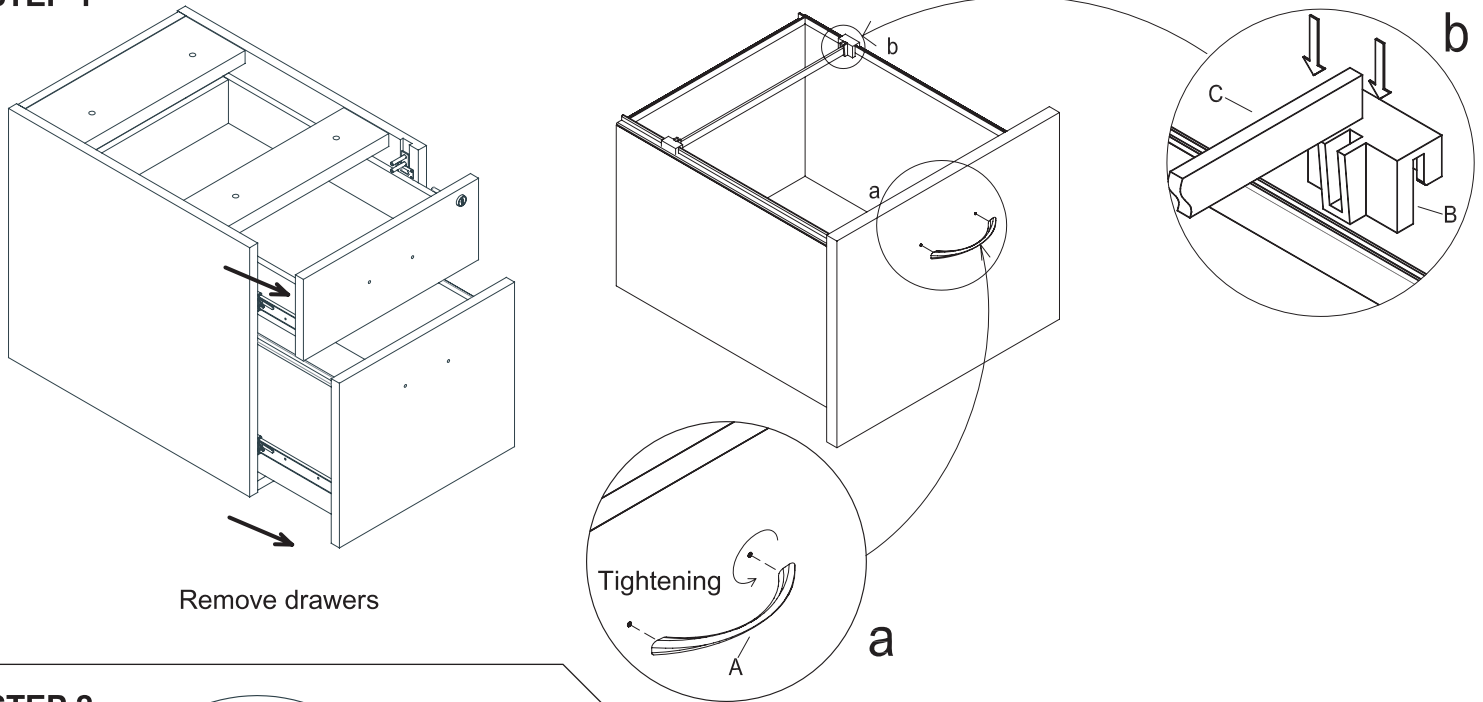
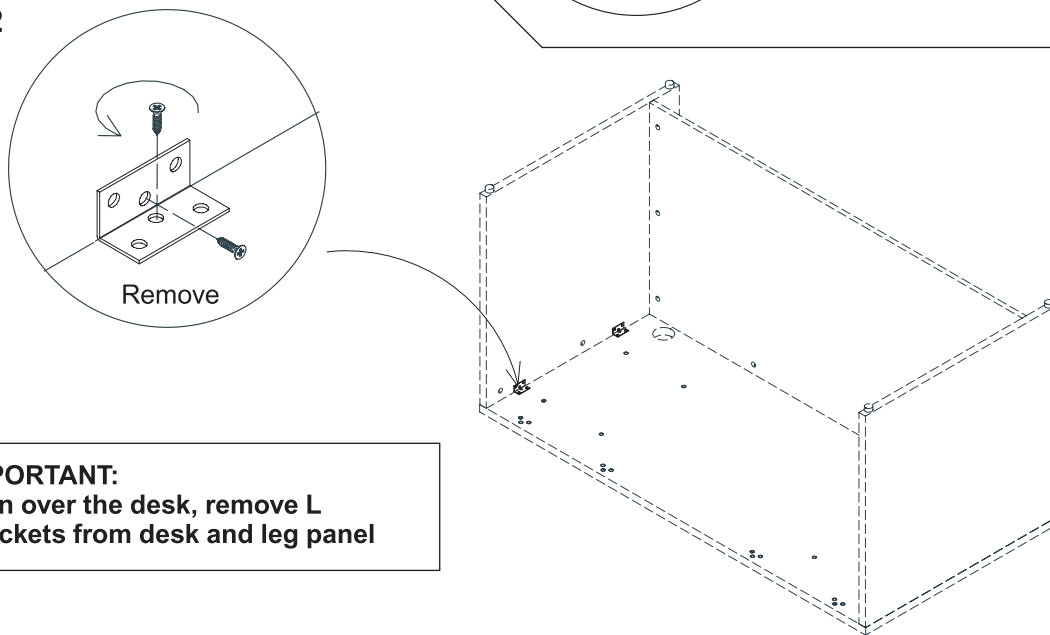

**IMPORTANT:**  
Turn over the desk, remove L brackets from desk and leg panel

### IMPORTANT NOTE:

- Place all laminated parts on a clean and smooth surface, such as a rug or carpet, to avoid the parts from being scratched.
- Check to be sure that you have all parts and hardware.
- Remove all wrapping materials, including staples and packing straps, before you start to assemble.
- Don't tighten all screws/bolts until all the pieces are completely assembled.
- Keep all hardware parts out of children's reach.
- It is recommended for 2 people to complete this assembly.

### STEP 3

Attach pedestal to top of Return or Desk. Use 4 sets (D) M6 x 40mm Screws + Washers Dia. 17mm provided.

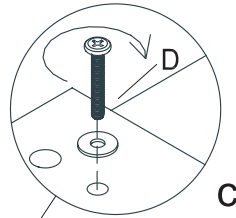

Screw M6 x 40mm  
Washers Dia. 17mm  
4 Sets  
DON'T OVER TIGHTEN

Leg Panel

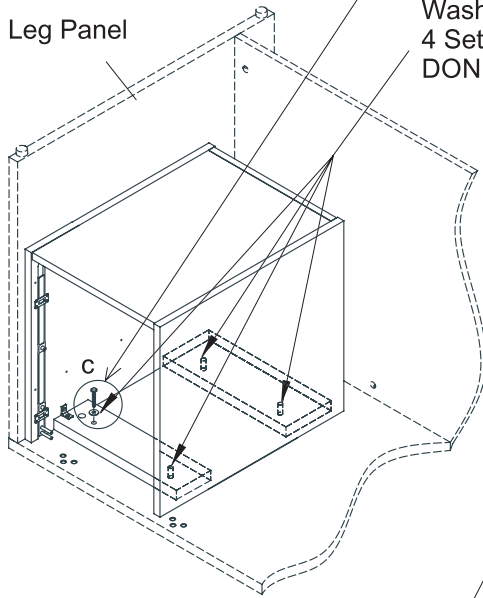

### STEP 4

To ensure pedestal safety, attach L Bracket to top and leg panel of desk or return before using.

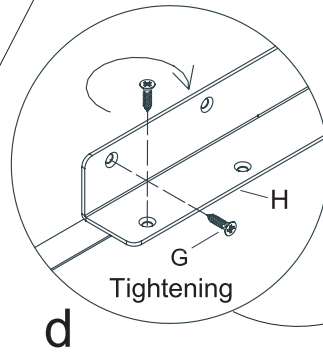

Attach long L bracket to leg panel of Desk or Return. Use 8 (G) #4 x 5/8" screws provided.

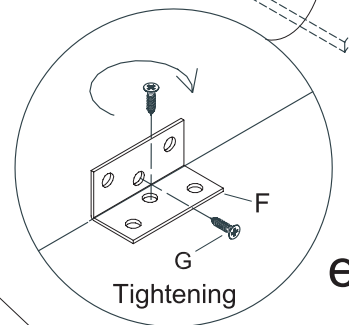
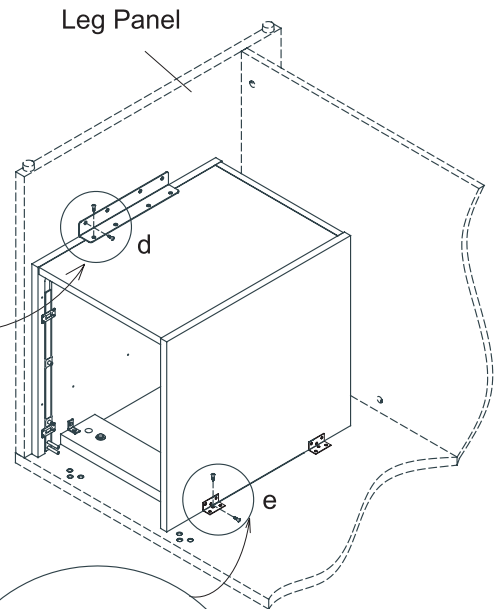





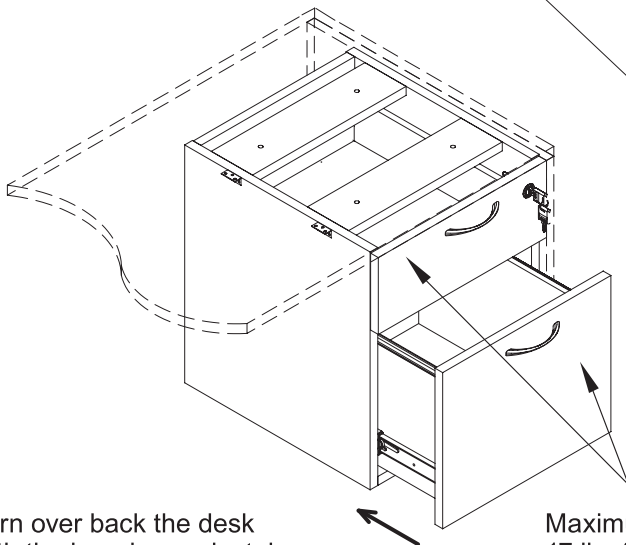

Attach 2 L brackets to top of Desk or Return. Use 12 (G) #4 x 5/8" screws provided.

### STEP 5

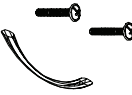

Turn over back the desk with the hanging pedestal and push in the drawer.

Maximum loading weight limit:  
17 lbs for top drawer;  
52 lbs for bottom drawer

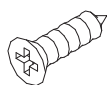
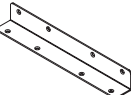
TUN005MH	TUN001FC	TUN002AB	TUN027SC		TUN013LB	TUN018SC	
 <p><b>A</b> Poignée métallique de 96mm en forme de coquille 2 Jeux</p>	 <p><b>B</b> Attache de dossier 2 mcx</p>	 <p><b>C</b> Barre de métal 300 x 16 x 3mm 1 mc</p>	 <p><b>D</b> Vis M6 x 40mm Rondelles de diamètre 17mm 4 jeux</p>	 <p><b>E</b> Clés 1 Jeu</p>	 <p><b>F</b> Support en L à 6 trous 2 mcx</p>	 <p><b>G</b> Vis #4 x 5/8" 12 mcx + 2 mcx supplémentaires</p>	 <p><b>H</b> Support en L à 8 trous 1 mc</p>

## ÉTAPE 1

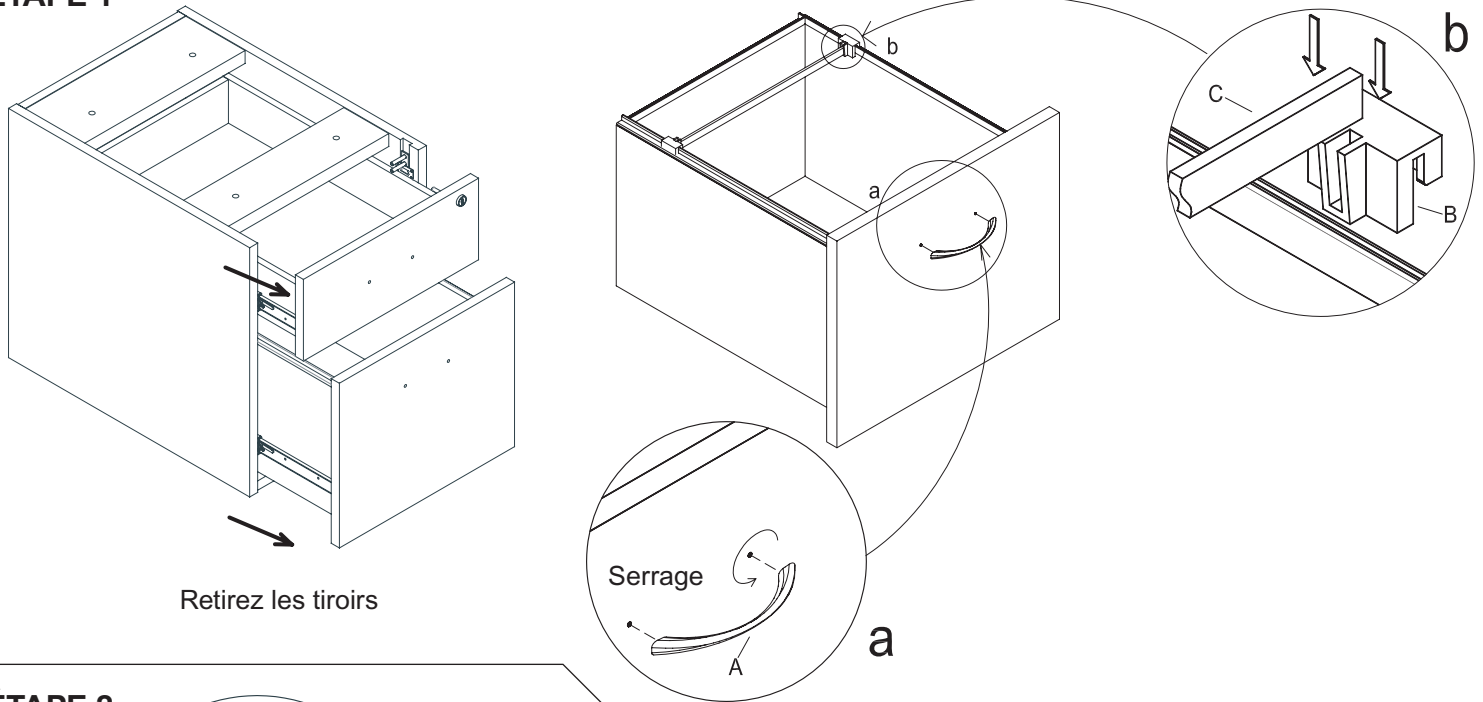

## ÉTAPE 2

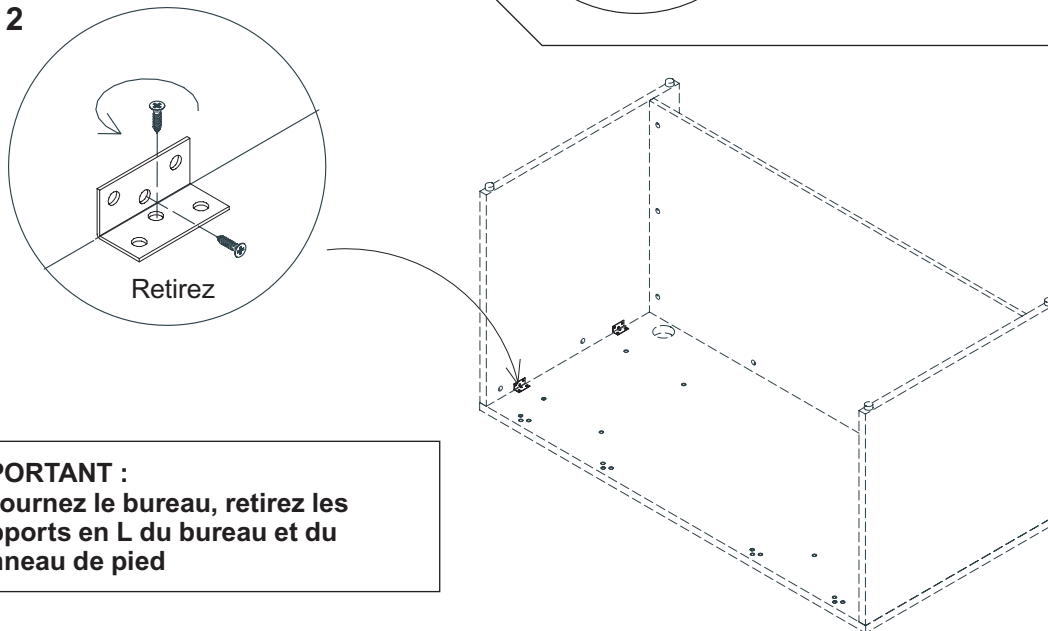

**IMPORTANT :**  
Retournez le bureau, retirez les supports en L du bureau et du panneau de pied

## NOTE IMPORTANT :

- Placez toutes les pièces contrecollées sur une surface propre et lisse, comme de la moquette ou un tapis, pour éviter de les érafler.
- S'assurer d'être en possession de toutes les pièces et de toute la quincaillerie.
- Retirer tout matériau d'emballage, y compris agrafes et sangles, avant de commencer le montage.
- Ne pas serrer toutes les vis ni tous les boulons avant que l'ensemble ne soit terminé
- Toute la quincaillerie doit rester hors de portée des enfants.
- Il est recommandé de travailler à 2 pour effectuer ce montage.

**ÉTAPE 3**

Fixez le caisson au dessus du retour ou du bureau. Utilisez 4 jeux de vis (D) M6 x 40 mm + les rondelles de dia. 17 mm fournies

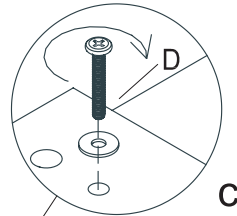

Vis M6 x 40mm Rondelles de diamètre 17mm 4 jeux  
**NE PAS SERRER EXCESSIVEMENT**

Panneau de pied

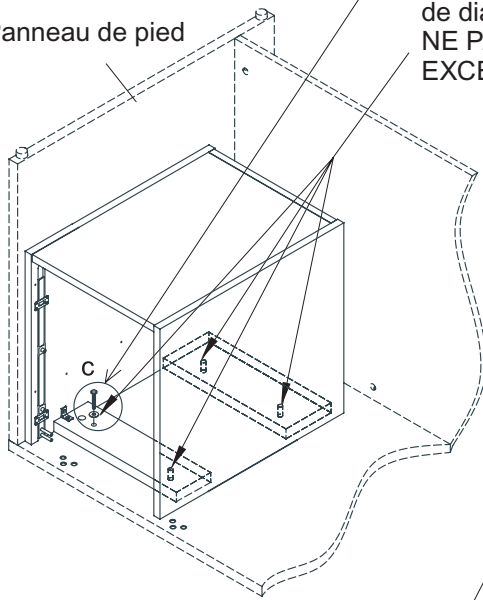
**ÉTAPE 4**

Pour garantir la sûreté du caisson, fixez un support en L au dessus et au panneau de pied du bureau ou retour avant utilisation.

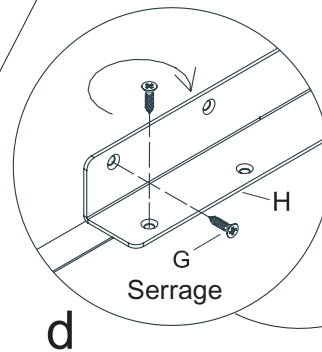

Fixez un support en L long au panneau de pied du bureau ou retour. Utilisez 8 vis (G) #4 x 5/8" fournies.

Panneau de pied

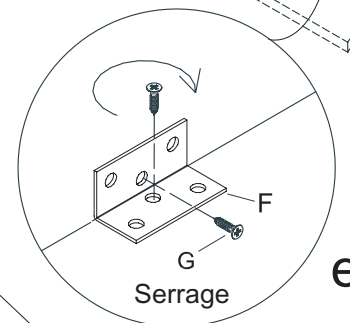
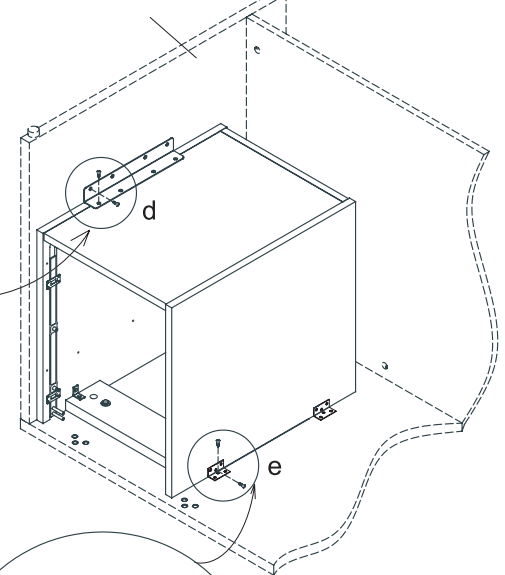



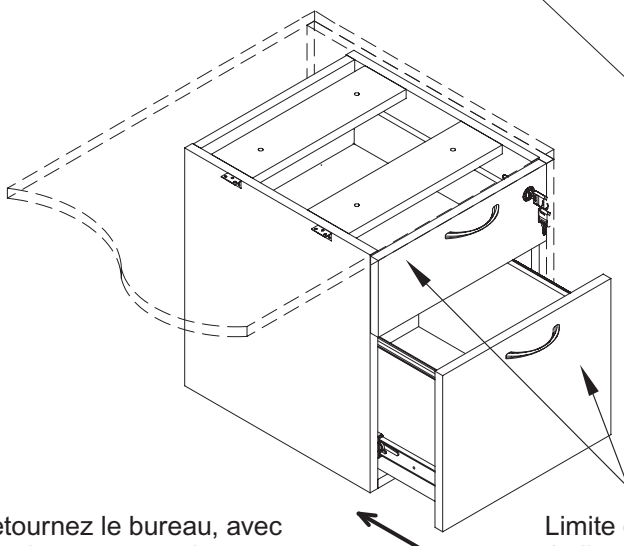

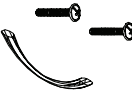

Fixez 2 supports en L au dessus du bureau ou retour. Utilisez 12 vis (G) #4 x 5/8" fournies.

**ÉTAPE 5**

Retournez le bureau, avec le caisson suspendu, et poussez le tiroir à l'intérieur.

Limite de charge maximum :  
17 lb pour le tiroir supérieur;  
52 lb pour le tiroir inférieur.

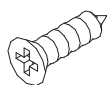
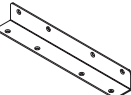
TUN005MH	TUN001FC	TUN002AB	TUN027SC		TUN013LB	TUN018SC	
<b>A</b>  Manija metálica curva de 96mm 2 juegos	<b>B</b>  Sujetador para archivo 2 pzas.	<b>C</b>  Barra de metal 300 x 16 x 3mm 1 pza.	<b>D</b>  Tornillos M6 x 40mm Arandelas de 17mm de diámetro 4 juegos	<b>E</b>  Llaves 1 juego	<b>F</b>  Soporte de escuadra de 6 orificios 2 pzas.	<b>G</b>  Tornillo #4 de 5/8" 12 pzas. + 2 pzas. extra	<b>H</b>  Soporte de escuadra de 8 orificios 1 pza.

## PASO 1

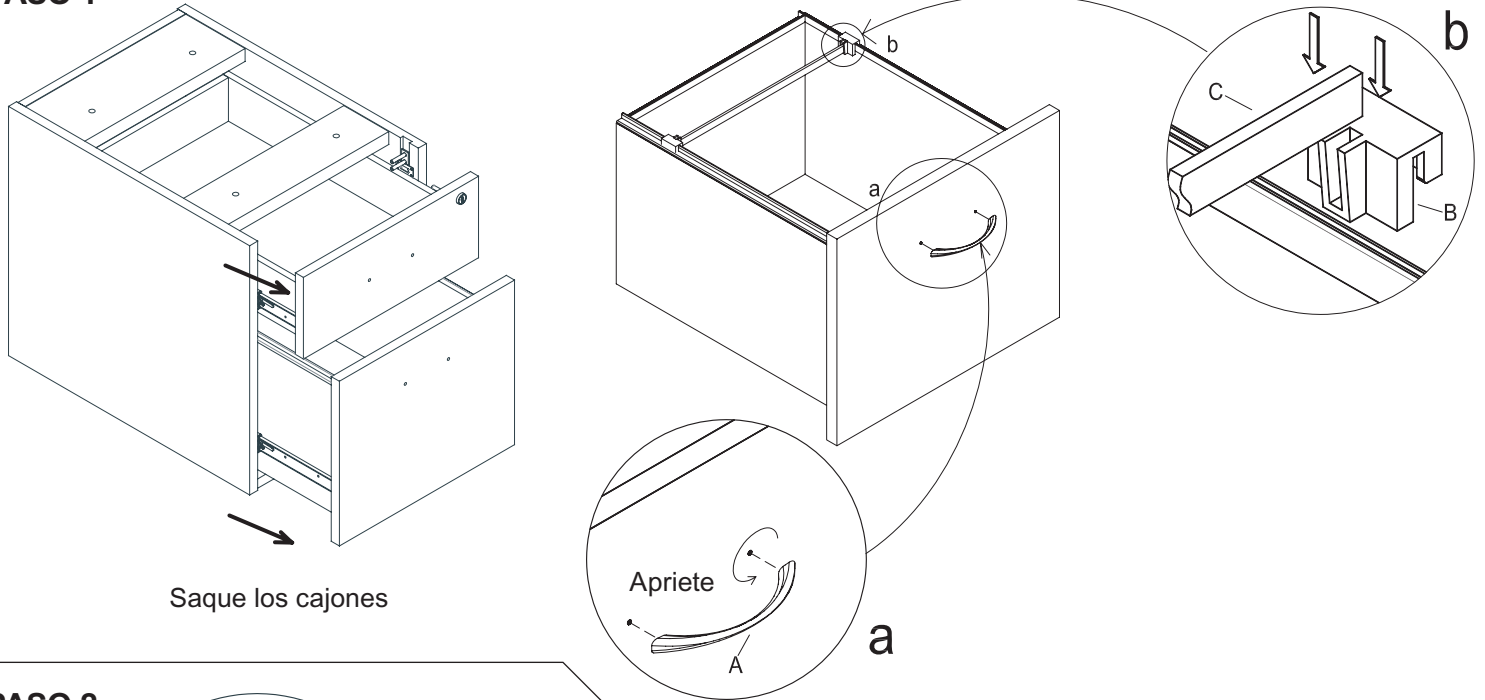

## PASO 2

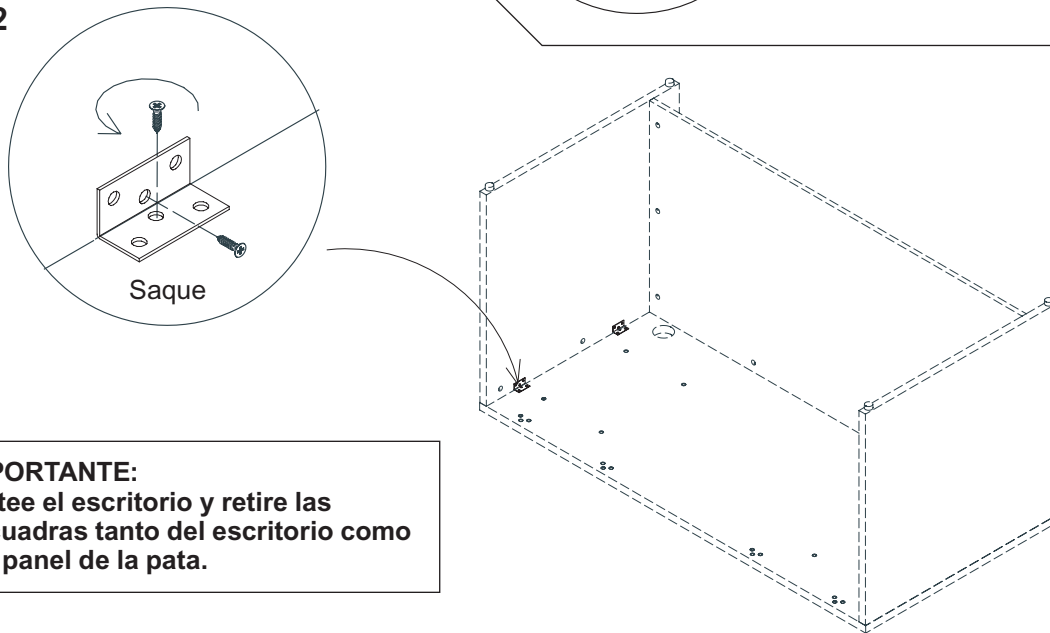

**IMPORTANTE:**  
Voltee el escritorio y retire las escuadras tanto del escritorio como del panel de la pata.

## NOTA IMPORTANTE:

- Coloque todas las partes laminadas sobre una superficie limpia y lisa (como un tapete o alfombra) para evitar que se rayen.
- Asegúrese de tener todas las partes y herrajes.
- Antes de empezar a ensamblar, remueva todos los materiales de empaque, incluyendo grapas y cintas.
- No apriete todos los tornillos y pernos hasta haber ensamblado por completo todas las piezas.
- Mantenga todo el herraje fuera del alcance de los niños.
- Se recomienda que dos personas realicen este ensamble.

### PASO 3

Una el pedestal a la superficie del escritorio o aparador. Use los 4 juegos incluidos de Tornillos M6 x 40 mm + Arandelas de 17 mm de diámetro (D).

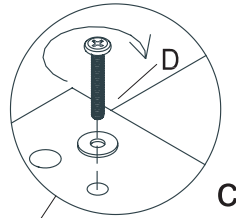

Tornillo M6 x 40 mm,  
Arandela de 17 mm de diámetro – 4 juegos.  
NO APRIETE DE MÁS

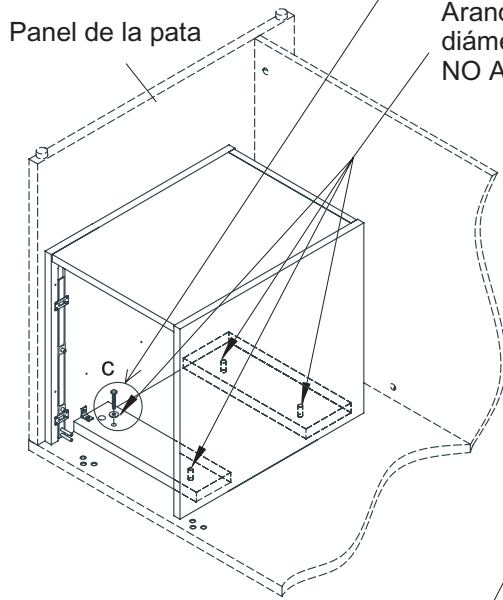

### PASO 4

Para asegurar el pedestal, una las escuadras tanto a la superficie como al panel de la pata del escritorio o aparador antes de usarlo.

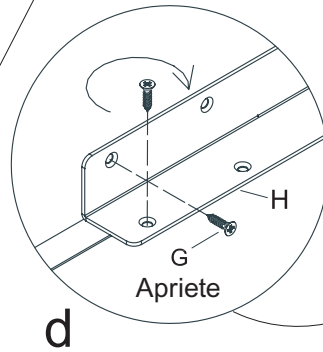

Una la escuadra larga al panel de la pata del escritorio o aparador. utilizar los 8 Tornillos #4 x 5/8" (G) proporcionados.

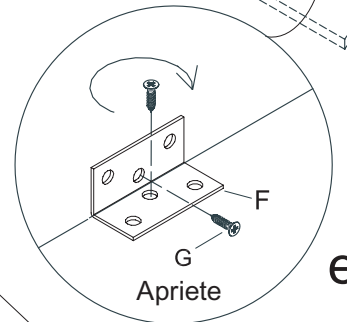
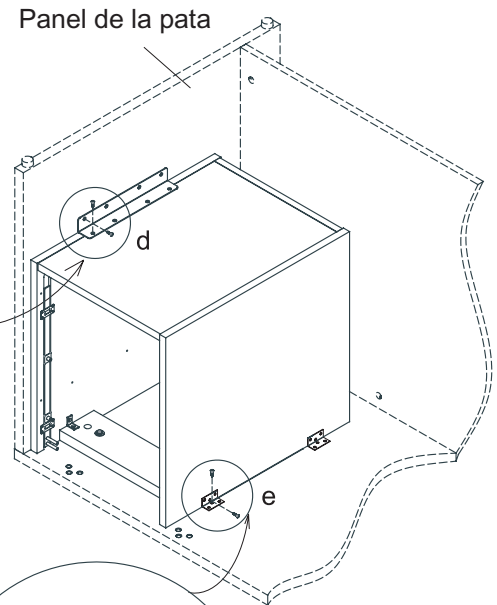

Una las 2 escuadras a la superficie del escritorio o aparador. Utilizar los 12 Tornillos #4 x 5/8" (G) proporcionados.

### PASO 5

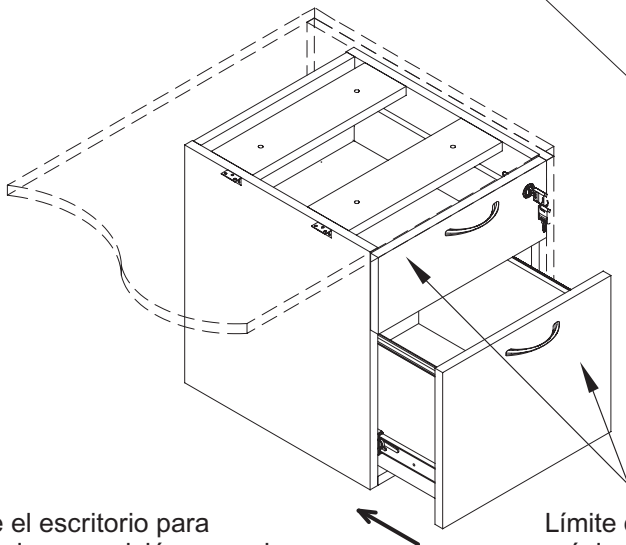

Voltee el escritorio para colocarlo en posición normal con el pedestal colgante e inserte el cajón.

Límite de peso de carga máxima: 17 libras en el cajón superior; 52 libras en el cajón inferior.

## Instructions

### **CALL US FIRST! DO NOT RETURN TO STORE.**

For immediate help with assembly or product information call our toll-free number: **1-888-598-7316** Mon. - Fri. 7am to 7 pm CST  
Our staff is ready to provide assistance. Damaged or missing parts ship from our facility in 1-2 business days.

Please provide the following information:

1. Full Name
2. Physical Address – do not include P.O. Box as our carriers cannot deliver to P.O. Boxes
3. Phone Number
4. Model Number
5. Part Number
6. Invoice #
7. Date of Purchase

Note: Our policy is to send all parts requests via normal ground transportation. If your requirements are to have these parts via overnight/next day, please provide your designated carrier and account number. Replacement panels are not available. If any damage has occurred during shipment please return the entire unit to place of purchase for credit and replacement. Original invoice may be required.

Before you begin:

Open, identify and count all parts prior to assembly. Lay out the parts on a non-abrasive surface such as carpet or blanket.

## Instructions

### **APPELEZ-NOUS D'ABORD! NE REVENEZ PAS AU MAGASIN.**

Pour obtenir une aide immédiate concernant l'assemblage ou des informations sur les produits, appelez notre numéro sans frais :  
**1-888-598-7316** Lun. - vend. 7h à 19 h CST Notre personnel vous attend pour vous offrir son aide.

Les pièces endommagées ou manquantes sont expédiées de nos locaux sous 1 à 2 jours ouvrables.

Veillez inclure les informations suivantes :

1. Nom complet
2. Adresse physique – ne pas inclure de boîte postale, car nos porteurs ne peuvent pas livrer à ces boîtes.
3. Numéro de téléphone
4. Numéro de modèle
5. Numéro de pièce
6. Numéro de facture
7. Date d'achat

Remarque : Notre politique est d'envoyer toutes les pièces demandées par transport terrestre normal. Si vous voulez recevoir ces pièces le jour suivant, indiquez votre porteur désigné ainsi qu'un numéro de compte. Nous ne fournissons pas de panneaux de rechange. En cas d'endommagement en cours de transport, renvoyez l'unité entière au lieu d'achat pour recevoir un crédit ou un échange. La facture originale vous sera peut-être demandée.

Avant de commencer:

Ouvrez, identifiez et comptez toutes les pièces avant l'assemblage. Disposez à plat les pièces sur une surface non abrasive comme un tapis ou une couverture.

## Instrucciones

### **¡LLÁMENOS PRIMERO! NO DEVUELVA EL PRODUCTO A LA TIENDA.**

Para recibir ayuda inmediata con el ensamble o información del producto, llame a nuestro número gratuito: **1-888-598-7316**

De lunes a viernes de 7 a.m. a 7 p.m., hora del Centro. Nuestro personal está preparado para brindarle asistencia.

Las partes dañadas o faltantes saldrán de nuestras instalaciones en el transcurso de 1 a 2 días hábiles.

Recuerde proporcionar la siguiente información:

1. Nombre completo
2. Domicilio físico – No incluya apartados postales debido a que no podemos realizar entregas en un apartado postal.
3. Número telefónico
4. Número de modelo
5. Número de parte
6. Número de factura
7. Fecha de compra

Nota: Nuestra política es enviar todas las solicitudes de partes por transporte terrestre regular. Si usted solicitó el envío de estas partes durante la noche o con entrega al día siguiente, proporcione el nombre de su compañía de mensajería y su número de cuenta. Los paneles de repuesto no están disponibles. Si ocurrió algún daño durante el envío, devuelva la unidad completa al lugar de compra para su devolución o reposición. Es posible que le pidan la factura original.

Antes de iniciar:

Abra, identifique y cuente todas las partes antes del ensamble. Coloque todas las partes en una superficie no abrasiva, como una alfombra o sábana.