

Model 810-LX Avenger Series Executive High-Back Chair

Parts Listing

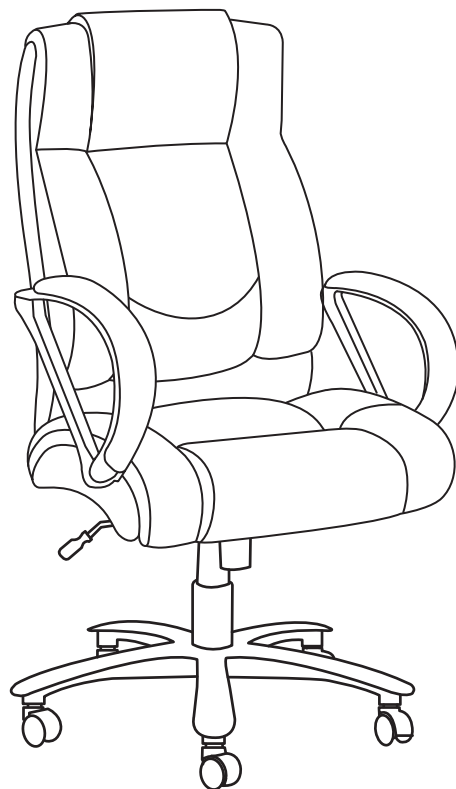

Assembly Instructions

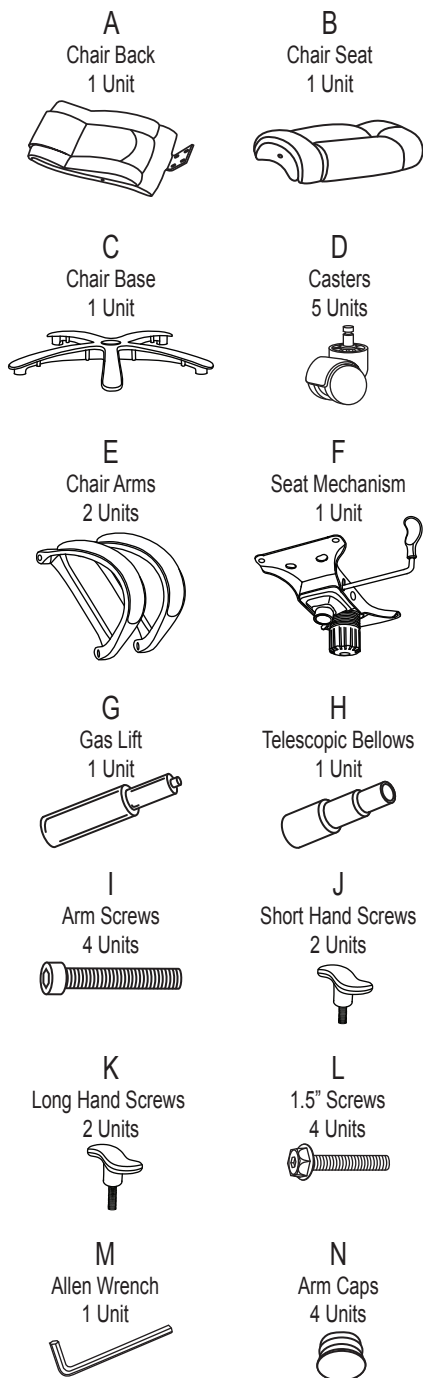

Tools Needed: Allen Wrench - Supplied
Please read all instructions before assembly.

- Step 1:** Insert Casters (D) into Chair Base (C). Insert Gas Lift (G) into Chair Base (C) and cover with Telescopic Bellows (H).
- Step 2:** Attach Seat Mechanism (F) to the Chair Seat (B) using 2 Short Hand Screws (J) at back of seat and using the 2 Long Hand Screws (K) at front of seat. Tension control knob should face front.
- Step 3:** Attach mounting plate on Chair Back (A) to Seat Mechanism (F) and Chair Seat (B) with 1.5" Screws (L), using Allen Wrench (M) that is provided.
- Step 4:** Attach Chair Arms (E) to Chair Back (A) and Chair Seat (B) using Arm Screws (I) and Allen Wrench (M). Cover screw holes with Arm Caps (N). Support bars on arms should be on the inside.
- Step 5:** Take entire chair frame and place Seat Mechanism (F) onto Gas Lift (G), and press down firmly to secure.

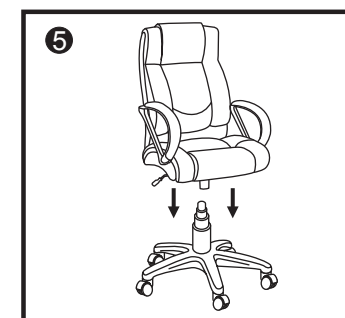
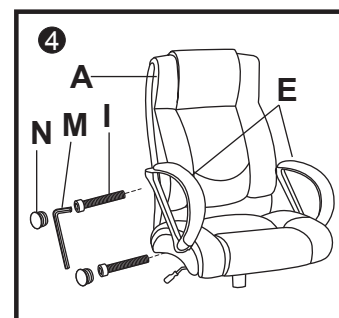
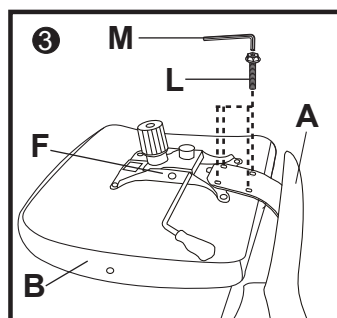
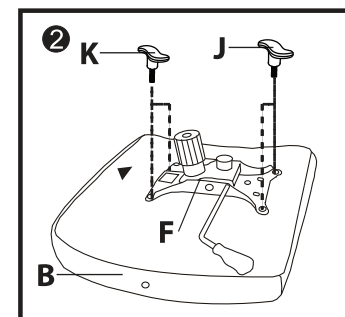
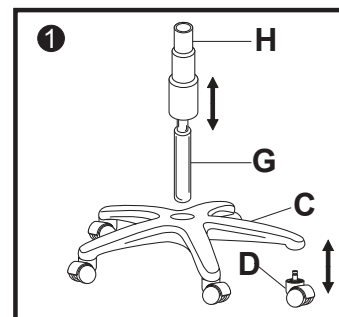

WEIGHT CAPACITY: 500 lbs.

Assembly Notes:

During assembly, hand tighten screws only. When all screws are in place, you may then tighten all screws completely.

CAUTION:

1. Do not use this chair as a step ladder.
2. Check for loose screws and tighten them every 6 months.

ofm
Furniture For The Real Office™

161 Tradition Trail,
Holly Springs, NC, 27540
800-520-7471 (voice)
919-303-6389 (voice)
919-362-4765 (fax)
www.ofmfurniture.com
support@ofminc.com