

SECTION A
SCALE: 1" = 1'-0"

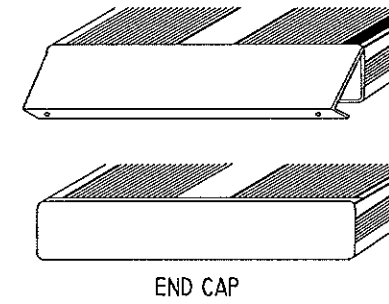

1. LOCATE THE CHANNEL END CAP AS SHOWN, WITH THE WIDER FLANGE ON BOTTOM.
2. TAP THE CHANNEL INTO PLACE WITH A RUBBER Mallet OR SOFT WOOD.
3. DRILL (2) No.8 x 3/4" TEK SCREWS W/ WEATHERCOATING THRU END CAP AND BOTTOM FLANGE OF PLANK

ENDCAP INSTALLATION DETAIL
SCALE: 3" = 1'-0"

LOCAL CODES AND SPECIFICATIONS WILL VARY FROM REGION TO REGION AND WILL ALSO CHANGE OVER TIME. IT IS THE BUYER'S RESPONSIBILITY TO CHECK LOCAL CODES FOR COMPLIANCE.

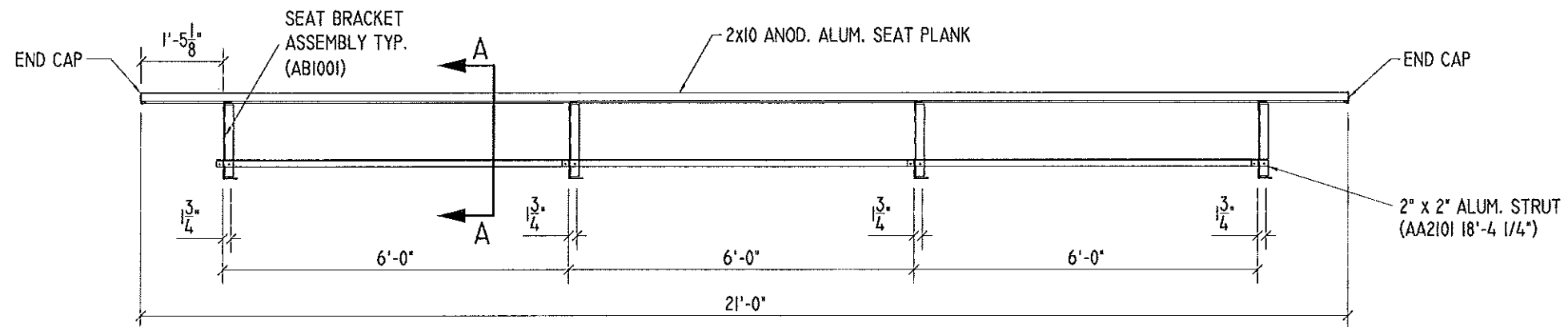

SPARTAN SERIES TEAM BENCH - MODEL SSA21
SURFACE MOUNTED (WITHOUT BACK REST)
SCALE: 3/8" = 1'-0"