

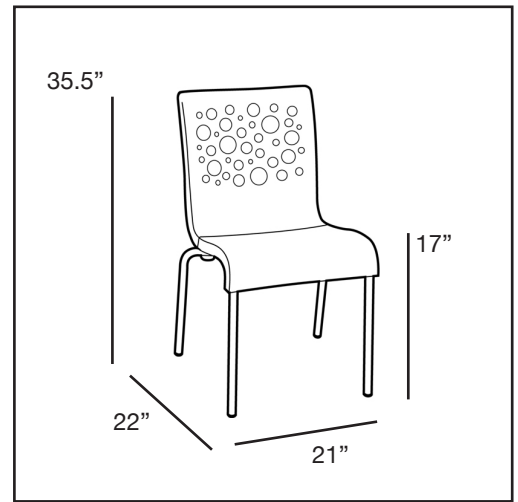

Tempo Stacking Chair



Product Specifications

Product Description	Reference Number	Color	UPC Code 014306	Weight Each (lbs.)	Master Pack	Master Pack Volume (cu. ft)
Tempo Stacking Chair	US021152	Fern Green/White	911830	16.83	4	15.41
	US021004	White/White	911847	16.83	4	15.41
	US021413	Beige/Taupe	911854	16.83	4	15.41
	US021017	Black/White	911861	16.83	4	15.41
	US021414	Red/White	911878	16.83	4	15.41
	US021019	Orange/White	912004	16.83	4	15.41
	US210151	Eggplant/Linen	918259	16.83	4	15.41
	US210187	Raspberry/Linen	919331	16.83	4	15.41
	US210196	Storm Blue/Linen	921655	16.83	4	15.41

Features & Benefits Warranty: 3 Yrs.

- Meets the performance standards of EN 581-1 and EN 581-2 for commercial use.
- Tested in accordance with and passes each test procedure utilized in ASTM F 1561-96 Class B performance standard for commercial seating.
- Unique, 2-color designer chair with a fun, bubbly personality in a sophisticated european design.
- Strong metal legs and hard wearing footpads for extra stability.
- Indoor stacking chair specifically designed for versatility of use in many contemporary environments.
- Perfect for use in food courts, cafeterias, airports, shopping malls, hospitals, colleges, and universities.
- Stacks for easy storage.
- Easy to clean with soap and water.
- Rated to 300 lbs. for safe commercial use.
- For interior use only

