



No.:

Date: 28-DEC-2012

Customer :

TECHNICAL PROPOSAL

Three-phase induction motor - Squirrel cage rotor

Product line : Jet Pump - NEMA 56 : Three-Phase - Threaded - TEFC (IP55)

Catalog Number : .5036ES3EJPR56J

List Price : \$282

Notes:

Performed by:

Checked:



No.:

Date: 28-DEC-2012

DATA SHEET

Three-phase induction motor - Squirrel cage rotor

Customer :
Product line : Jet Pump - NEMA 56 : Three-Phase - Threaded - TEFC (IP55)

Frame : B56
Output : 0.5 HP
Frequency : 60 Hz
Poles : 2
Full load speed : 3470
Slip : 3.61 %
Voltage : 208-230/460 V
Rated current : 1.75-1.70/0.850 A
Locked rotor current : 13.6/6.80 A
Locked rotor current (I_L/I_n) : 8.0
No-load current : 1.00/0.500 A
Full load torque : 0.747 lb.ft
Locked rotor torque : 430 %
Breakdown torque : 440 %
Design : A
Insulation class : F
Temperature rise : 80 K
Locked rotor time : 10 s (hot)
Service factor : 1.15 (1.00 at 208V)
Duty cycle : S1
Ambient temperature : -20°C - +40°C
Altitude : 1000
Degree of Protection : IP55
Approximate weight : 23 lb
Moment of inertia : 0.03156 sq.ft.lb
Noise level : ---

	D.E.	N.D.E.	Load	Power factor	Efficiency (%)
Bearings	6203 2RS	6202 2RS	100%	0.80	70.0
Regreasing interval	---	---	75%	0.74	66.0
Grease amount	---	---	50%	0.64	57.5

Notes:

Performed by

Checked



No.:

Date: 28-DEC-2012

PERFORMANCE CURVES RELATED TO RATED OUTPUT

Three-phase induction motor - Squirrel cage rotor

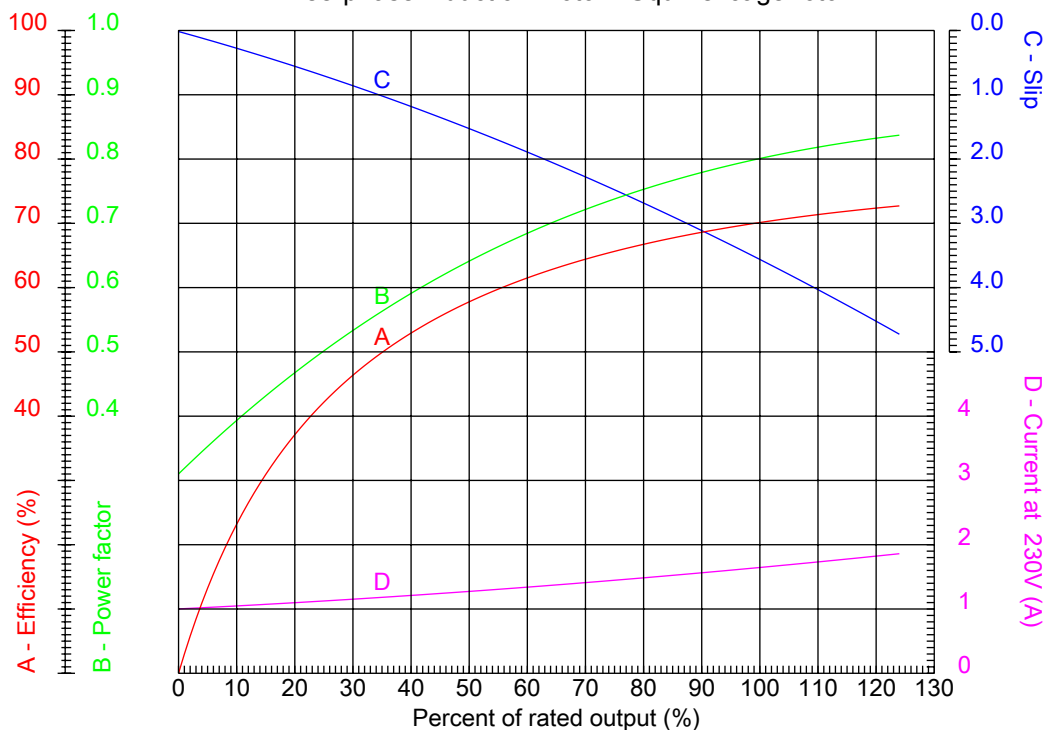

Customer :
 Product line : Jet Pump - NEMA 56 : Three-Phase - Threaded - TEFC (IP55)

Frame	: B56	Locked rotor current (I _l /I _n)	: 8.0
Output	: 0.5 HP	Duty cycle	: S1
Frequency	: 60 Hz	Service factor	: 1.15 (1.00 at 208V)
Full load speed	: 3470	Design	: A
Voltage	: 208-230/460 V	Locked rotor torque	: 430 %
Rated current	: 1.75-1.70/0.850 A	Breakdown torque	: 440 %
Insulation class	: F		

Notes:

Performed by

Checked



No.:

Date: 28-DEC-2012

CHARACTERISTIC CURVES RELATED TO SPEED

Three-phase induction motor - Squirrel cage rotor

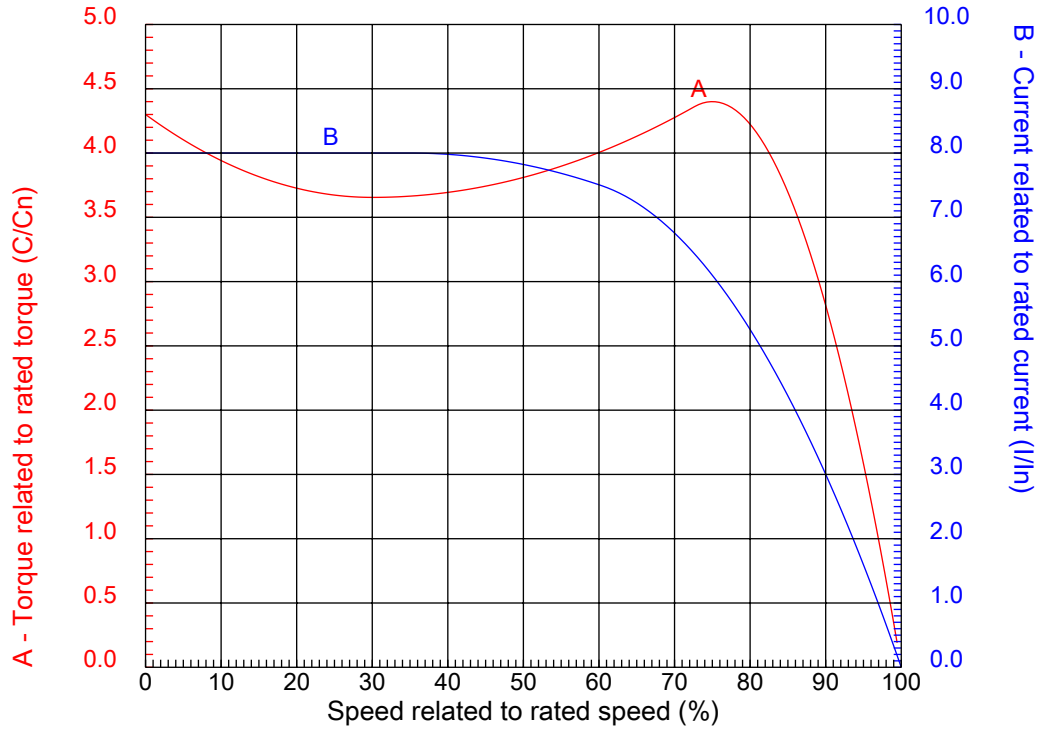

Customer :
Product line : Jet Pump - NEMA 56 : Three-Phase - Threaded - TEFC (IP55)

Frame	: B56	Locked rotor current (I _l /I _n)	: 8.0
Output	: 0.5 HP	Duty cycle	: S1
Frequency	: 60 Hz	Service factor	: 1.15 (1.00 at 208V)
Full load speed	: 3470	Design	: A
Voltage	: 208-230/460 V	Locked rotor torque	: 430 %
Rated current	: 1.75-1.70/0.850 A	Breakdown torque	: 440 %
Insulation class	: F		

Notes:

Performed by

Checked

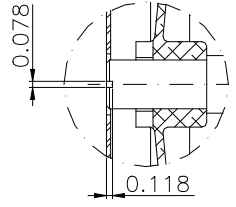
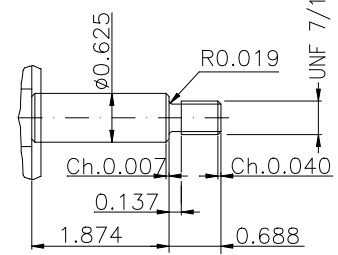
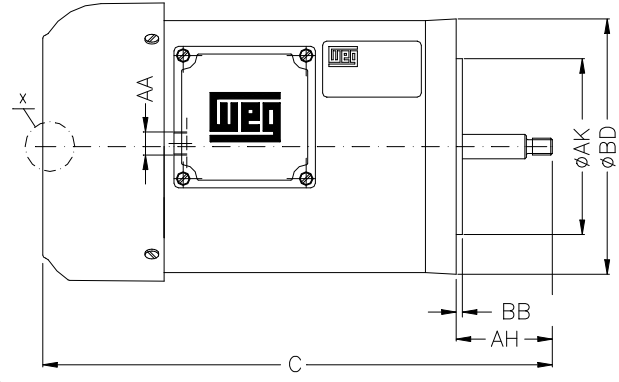
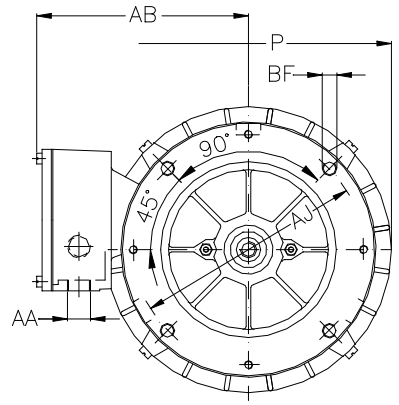

THREE-PHASE, FORM J, WITH INTERNAL
 THREAD OF 1/4"x28 UNF AT SHAFT-END,
 FOR CLAMPING THE PUMP ROTOR.

DETAIL X

Notes:

Performed by:

Checked:

Customer:

Jet Pump - NEMA 56 : Three-Phase - Threaded - TEFC (IP55)

C	P	AB	AA	Flange
11.614	7.323	5.433	NPT 1/2"	FC-149
AJ	AK	BD	BF	BB
5.874	4.500	6.535	UNC 3/8"x16-2B	0.157
BC	AH			

Three-phase induction motor
 Frame B56 - IP55

28-DEC-2012

