



No.:

Date: 19-DEC-2012

Customer :

TECHNICAL PROPOSAL

Three-phase induction motor - Squirrel cage rotor

Product line : Three-Phase : ODP (IP21/IP23) - NEMA Premium Efficiency

Catalog Number : 00158OT3H145T

List Price : \$449

Notes:

Performed by:

Checked:



No.:

Date: 19-DEC-2012

DATA SHEET

Three-phase induction motor - Squirrel cage rotor

Customer :
Product line : Three-Phase : ODP (IP21/IP23) - NEMA Premium Efficiency

Frame : E143/5T
Output : 1.5 HP
Frequency : 60 Hz
Poles : 4
Full load speed : 1740
Slip : 3.33 %
Voltage : 575 V
Rated current : 1.76 A
Locked rotor current : 15.8 A
Locked rotor current (I_L/I_n) : 9.0
No-load current : 1.12 A
Full load torque : 4.47 lb.ft
Locked rotor torque : 360 %
Breakdown torque : 340 %
Design : B
Insulation class : F
Temperature rise : 80 K
Locked rotor time : 15 s (hot)
Service factor : 1.15
Duty cycle : S1
Ambient temperature : -20°C - +40°C
Altitude : 1000
Degree of Protection : IP21
Approximate weight : 44 lb
Moment of inertia : 0.15970 sq.ft.lb
Noise level : ---

	D.E.	N.D.E.	Load	Power factor	Efficiency (%)
Bearings	6205 ZZ	6204 ZZ	100%	0.75	86.5
Regreasing interval	---	---	75%	0.66	85.5
Grease amount	---	---	50%	0.52	82.5

Notes:

Performed by

Checked



No.:

Date: 19-DEC-2012

PERFORMANCE CURVES RELATED TO RATED OUTPUT Three-phase induction motor - Squirrel cage rotor

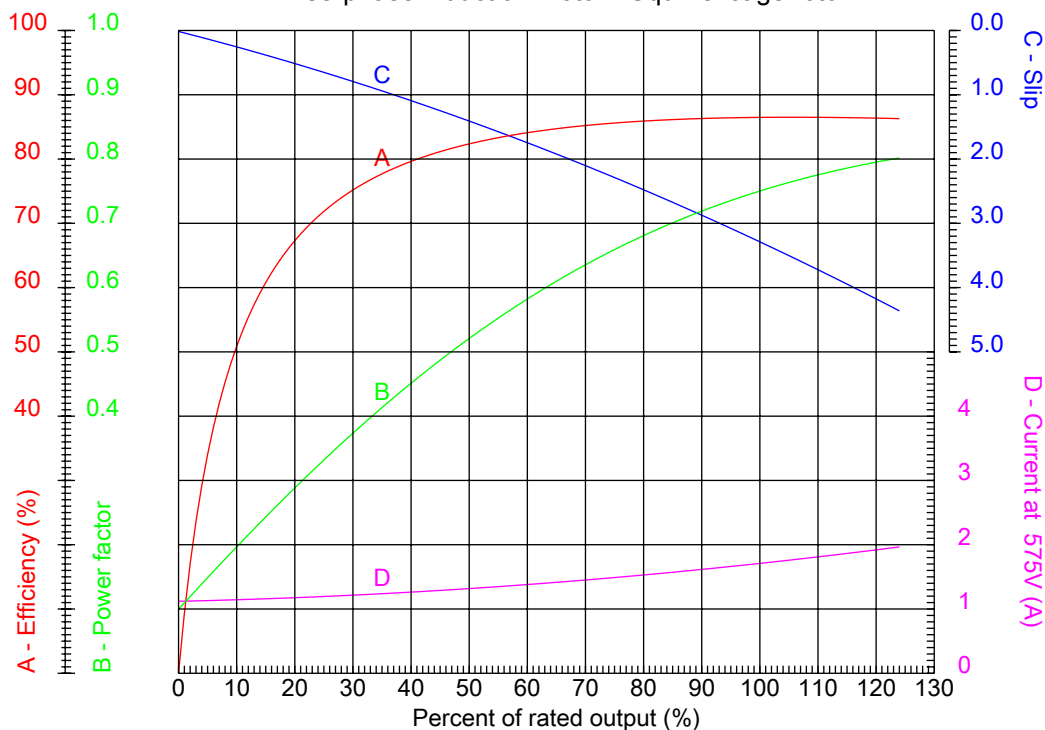

Customer :
Product line : Three-Phase : ODP (IP21/IP23) - NEMA Premium Efficiency

Frame	: E143/5T	Locked rotor current (I _l /I _n)	: 9.0
Output	: 1.5 HP	Duty cycle	: S1
Frequency	: 60 Hz	Service factor	: 1.15
Full load speed	: 1740	Design	: B
Voltage	: 575 V	Locked rotor torque	: 360 %
Rated current	: 1.76 A	Breakdown torque	: 340 %
Insulation class	: F		

Notes:

Performed by

Checked



No.:

Date: 19-DEC-2012

CHARACTERISTIC CURVES RELATED TO SPEED Three-phase induction motor - Squirrel cage rotor

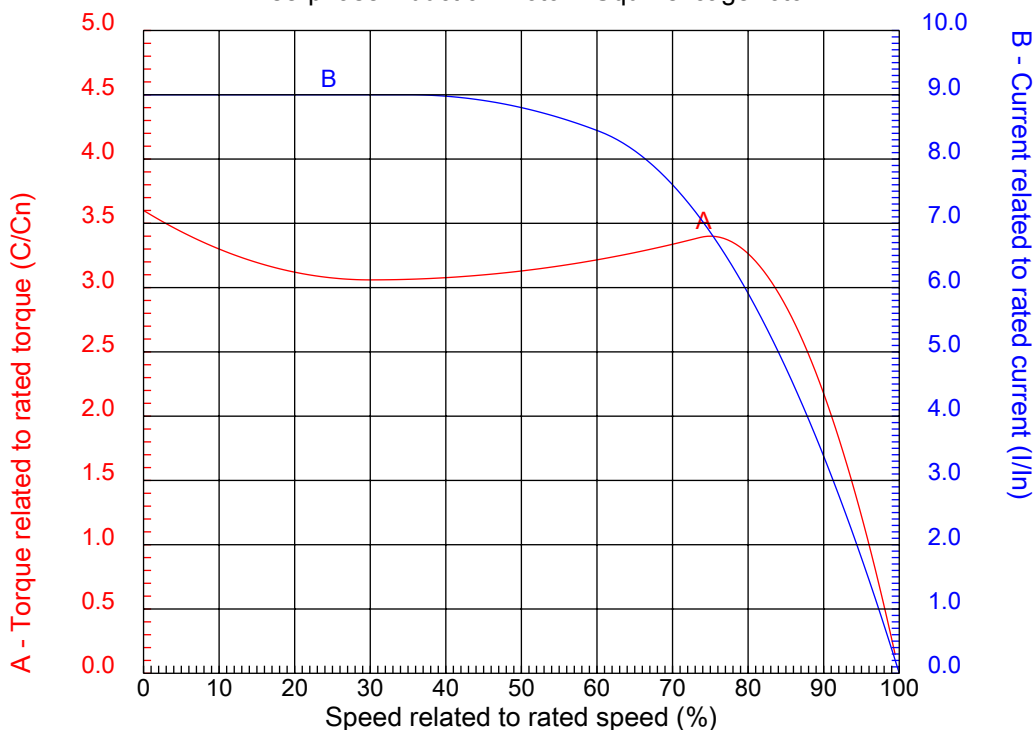

Customer :
Product line : Three-Phase : ODP (IP21/IP23) - NEMA Premium Efficiency

Frame	: E143/5T	Locked rotor current (I _l /I _{ln})	: 9.0
Output	: 1.5 HP	Duty cycle	: S1
Frequency	: 60 Hz	Service factor	: 1.15
Full load speed	: 1740	Design	: B
Voltage	: 575 V	Locked rotor torque	: 360 %
Rated current	: 1.76 A	Breakdown torque	: 340 %
Insulation class	: F		

Notes:

Performed by

Checked

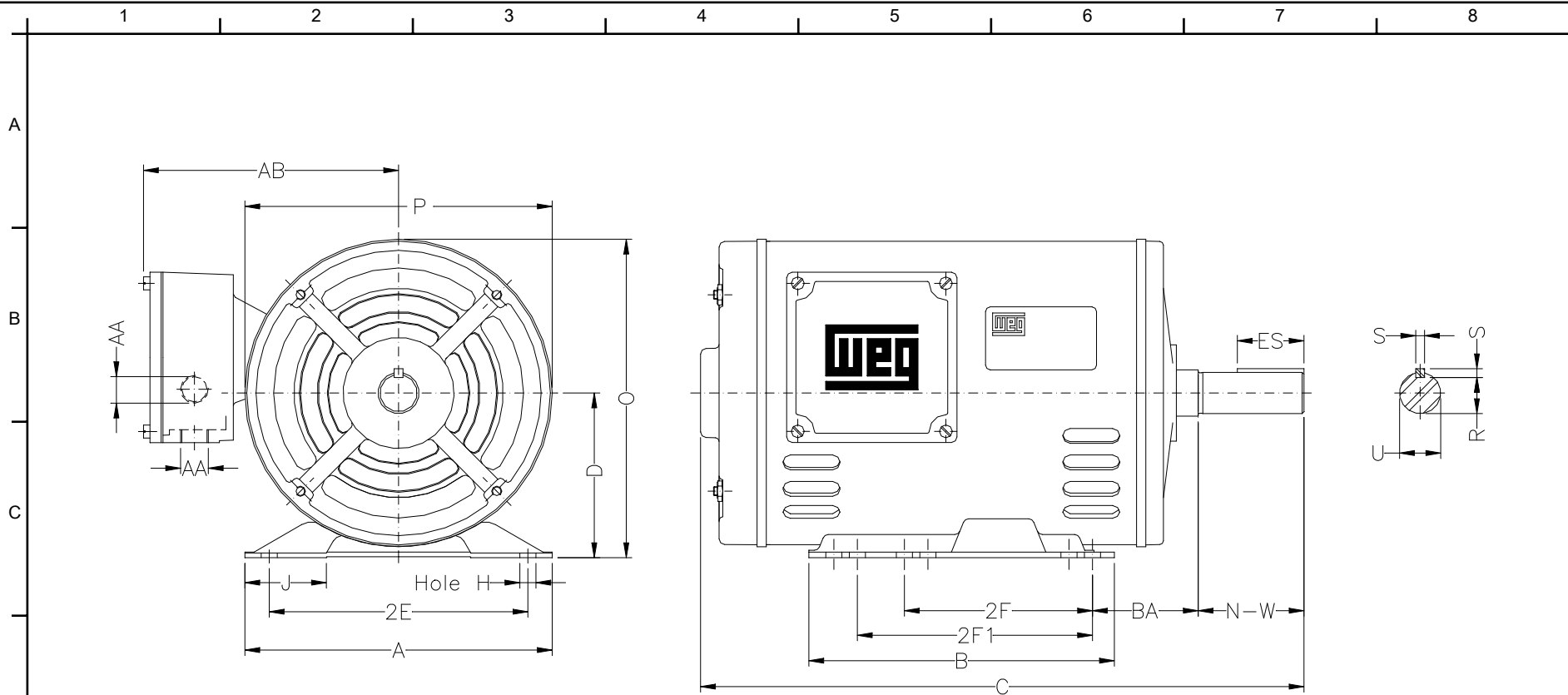

Notes:

Performed by:

Checked:

Customer:

Three-Phase : ODP (IP21/IP23) - NEMA Premium Efficiency

Three-phase induction motor
Frame E143/5T - IP21

19-DEC-2012



2E 5.500	A 6.535	2F 4.000/5.000	B 6.496	BA 2.250
J 1.732	K 1.988	P 6.535	ES 1.417	depth 0.187
S 0.187	D 3.500	N-W 2.250	G 0.120	U 0.8750
O 6.772	T 653.228	HD 660	R 0.766	H 0.342
C 12.047	AA 2XNPT 1/2"	Flange C	AJ 5.874	AK 4.500
BD 6.535	BF UNC 3/8"x16	BB 0.157	BC ---	AH