



No.:

Date: 21-DEC-2012

Customer :

TECHNICAL PROPOSAL

Three-phase induction motor - Squirrel cage rotor

Product line : W22 Super Premium

Catalog Number : 15012EG3G449T-W22

List Price : \$22,703

Notes:

Performed by:

Checked:



No.:

Date: 21-DEC-2012

## DATA SHEET

### Three-phase induction motor - Squirrel cage rotor

Customer :  
Product line : W22 Super Premium

Frame : 447/9T  
Output : 150 HP  
Frequency : 60 Hz  
Poles : 6  
Full load speed : 1190  
Slip : 0.83 %  
Voltage : 460 V  
Rated current : 179 A  
Locked rotor current : 1340 A  
Locked rotor current (I<sub>L</sub>/I<sub>n</sub>) : 7.5  
No-load current : 86.0 A  
Full load torque : 653 lb.ft  
Locked rotor torque : 260 %  
Breakdown torque : 320 %  
Design : A  
Insulation class : F  
Temperature rise : 80 K  
Locked rotor time : 22 s (hot)  
Service factor : 1.25  
Duty cycle : S1  
Ambient temperature : -20°C - +40°C  
Altitude : 1000  
Degree of Protection : IP55  
Approximate weight : 2256 lb  
Moment of inertia : 153.82 sq.ft.lb  
Noise level : 69 dB(A)

	D.E.	N.D.E.	Load	Power factor	Efficiency (%)
Bearings	6322 C3	6319 C3	100%	0.80	96.2
Regreasing interval	11000 h	13000 h	75%	0.74	95.8
Grease amount	60 g	45 g	50%	0.62	95.0

Notes:

Performed by

Checked



No.:

Date: 21-DEC-2012

PERFORMANCE CURVES RELATED TO RATED OUTPUT  
Three-phase induction motor - Squirrel cage rotor

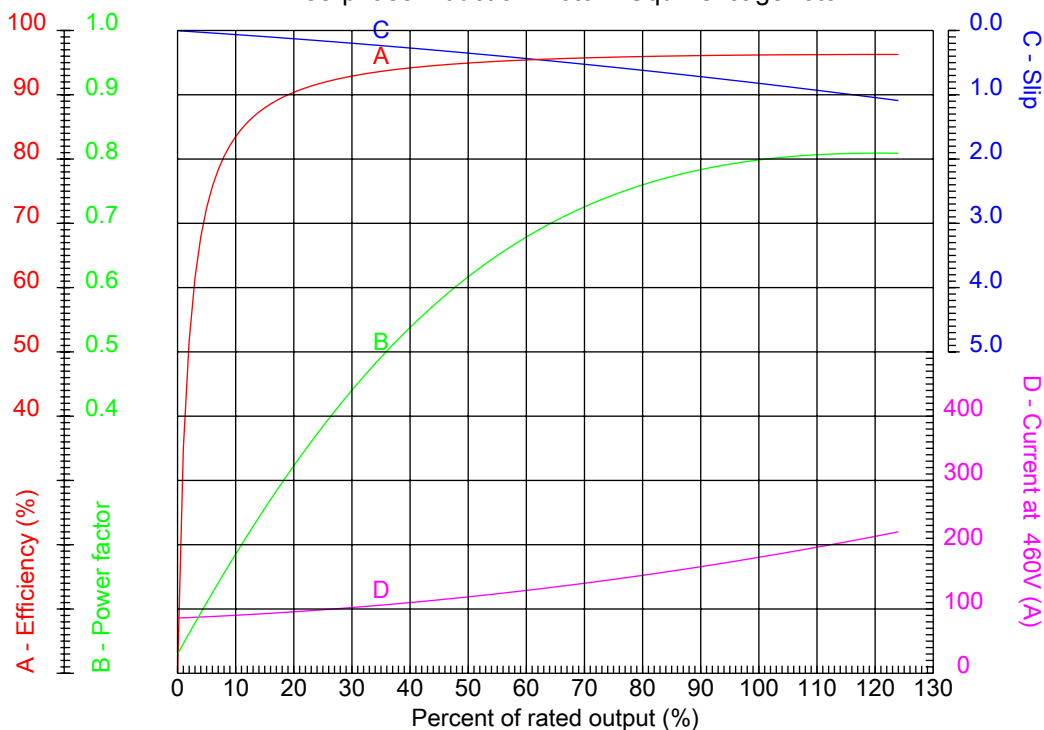

Customer :  
Product line : W22 Super Premium

Frame	: 447/9T	Locked rotor current (I <sub>l</sub> /I <sub>n</sub> )	: 7.5
Output	: 150 HP	Duty cycle	: S1
Frequency	: 60 Hz	Service factor	: 1.25
Full load speed	: 1190	Design	: A
Voltage	: 460 V	Locked rotor torque	: 260 %
Rated current	: 179 A	Breakdown torque	: 320 %
Insulation class	: F		

Notes:

Performed by

Checked



No.:

Date: 21-DEC-2012

### CHARACTERISTIC CURVES RELATED TO SPEED

Three-phase induction motor - Squirrel cage rotor

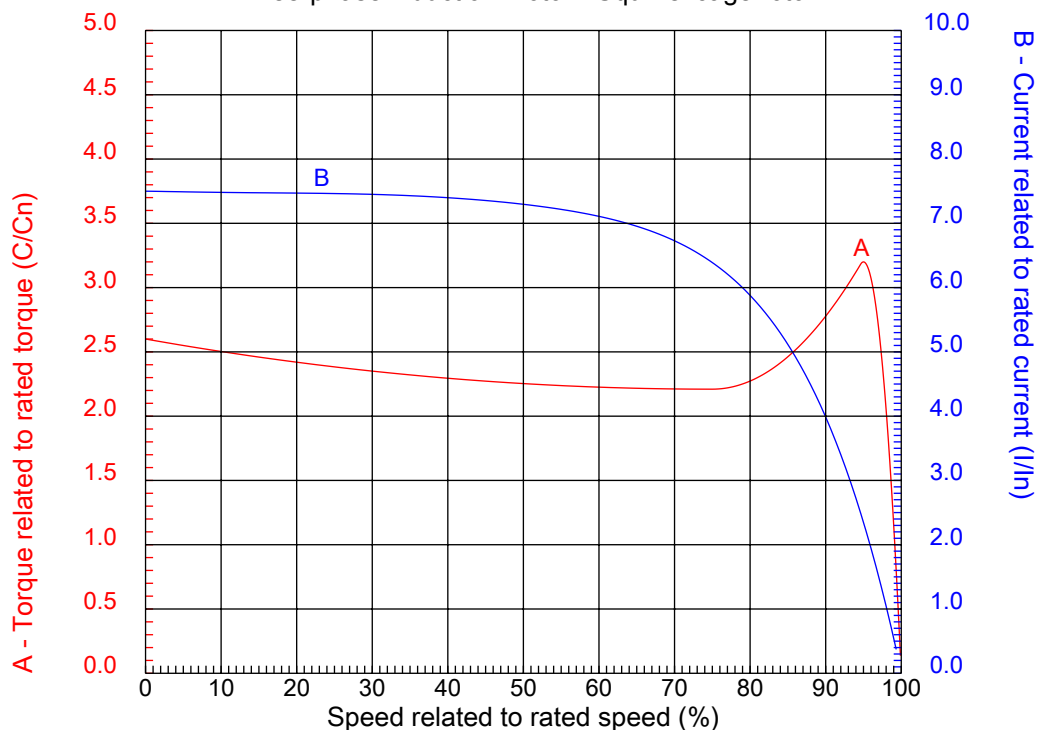

Customer :  
Product line : W22 Super Premium

Frame	: 447/9T	Locked rotor current (I <sub>l</sub> /I <sub>n</sub> )	: 7.5
Output	: 150 HP	Duty cycle	: S1
Frequency	: 60 Hz	Service factor	: 1.25
Full load speed	: 1190	Design	: A
Voltage	: 460 V	Locked rotor torque	: 260 %
Rated current	: 179 A	Breakdown torque	: 320 %
Insulation class	: F		

Notes:

Performed by

Checked

1 2 3 4 5 6 7 8

A

B

C

D

E

F

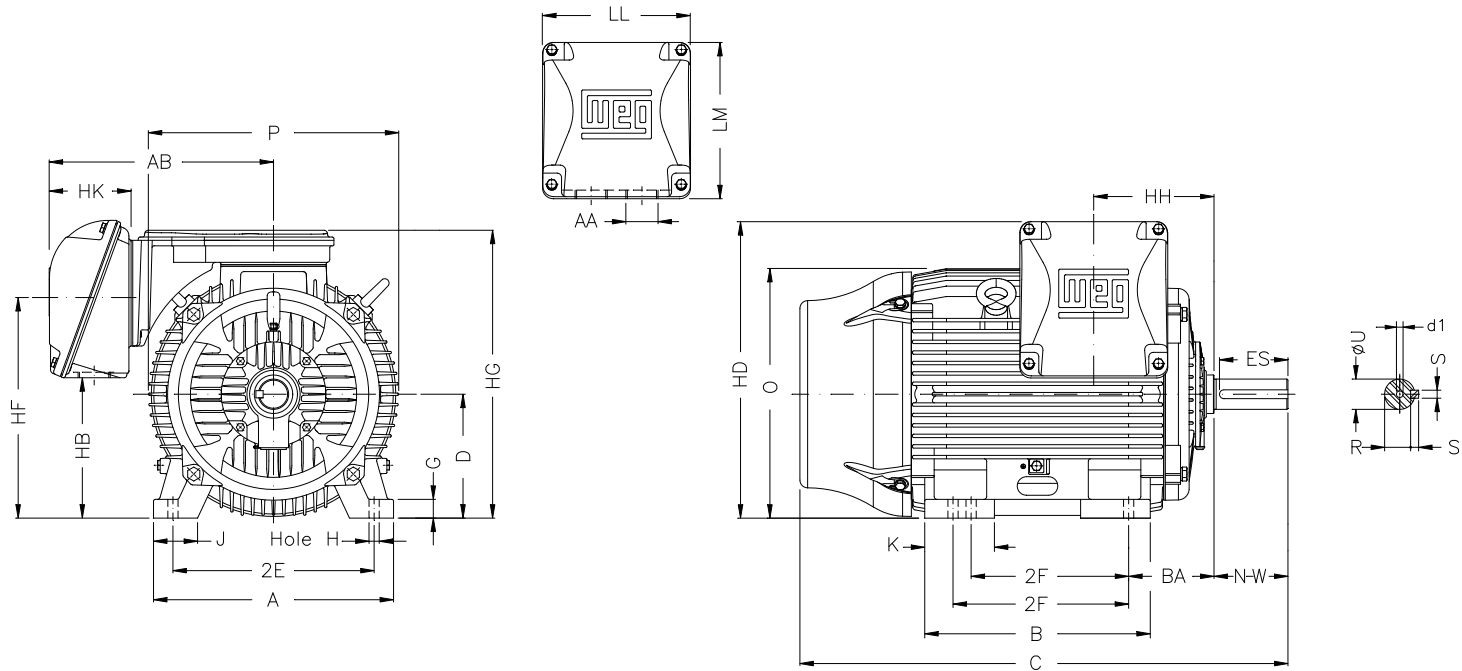

Notes:

Performed by:

Checked:

Customer:

W22 Super Premium

Three-phase induction motor

Frame 447/9T - IP55

21-DEC-2012



2E	J	A	P	AB
18.000	3.937	21.929	23.583	20.670
2F	K	B	BA	U
20.000/25.000	11.77	31.535	7.500	3.375
N-W	ES	S	R	depth
8.500	7.087	0.875	2.880	0.875
D	G	HB	O	T
11.000	1.630	12.598	22.795	7.378
HD	HF	HG	HH	HK
30.173	20.724	26.850	11.803	6.968
H	C	LL	LM	AA
0.810	56.338	14.646	15.040	2XNPT 3"
d1	d2	Flange	AJ	AK
DUNC 3/4"-10	DUNC 3/4"-10	FD-508	20.000	18.000
BD	BF	BB		
21.65	0.828	0.203		