

# Compression Shear Mounts

NVS series

## NVS Compression shear mounts

Leveling solution specifically for applications having both compression and shear loads. Precision fitted neoprene inserts provide efficient dampening of shock and shear forces.

### Recommended for:

lathes, milling machines, punch presses, Heavy duty printing machinery, shears, brakes, injection mold machines, grinders and other industrial equipment where bolting to the floor is not required.

### Features:

- Built in leveling device enables quick, easy and precise leveling of machinery.
- Circular grooves on base of insert firmly anchor the machine to the floor, preventing creeping or walking.
- Effectively isolates vertical and horizontal forces.
- Controls vibration, shock and noise.
- Resistant to most oils and cleaning compounds.
- Meets OSHA requirements for anchoring machinery.
- Economical, durable and saves on installation cost.
- Strong, reliable construction provides long life.

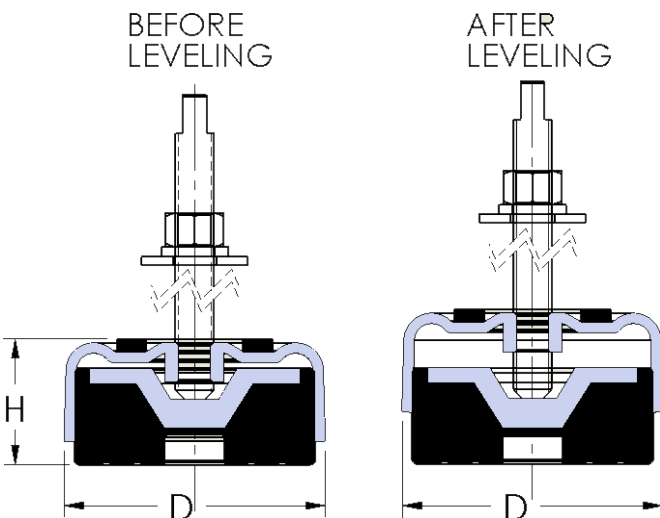

LOAD vs DEFLECTION

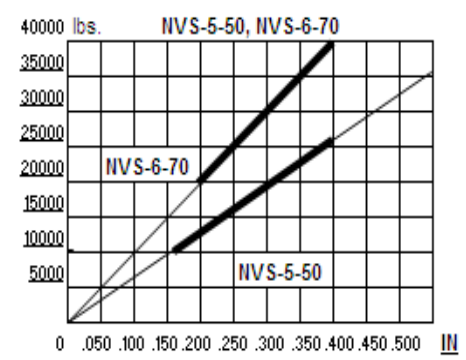
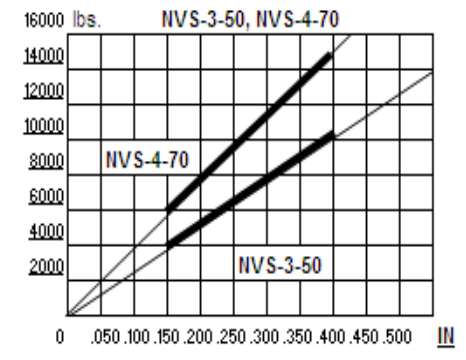
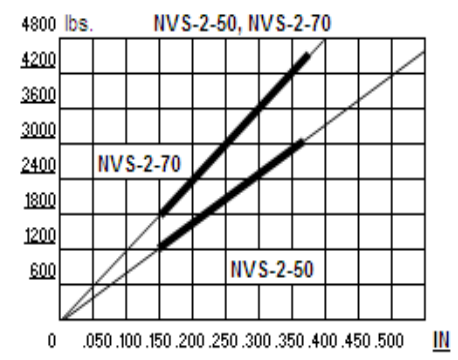
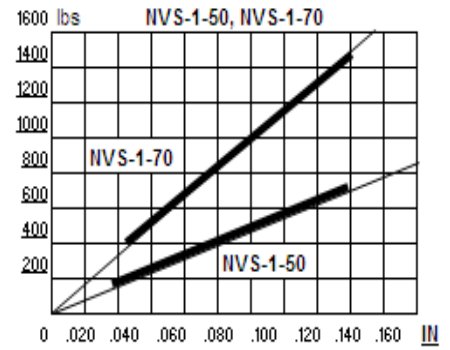

| Type     | Maximum load in (lbs) |                  | Level Adjustment | Bolt Size       | Mount (in) |       |
|----------|-----------------------|------------------|------------------|-----------------|------------|-------|
|          | Non-Impact Machinery  | Impact Machinery |                  |                 | D          | H     |
| NVS-1-50 | 750                   | 500              | 3/8"             | 1/2-13 x 6"     | 3-3/8      | 1-3/4 |
| NVS-1-70 | 1,500                 | 1,000            | 3/8"             | 1/2-13 x 6"     | 3-3/8      | 1-3/4 |
| NVS-2-50 | 3,000                 | 2,000            | 1/2"             | 5/8-11 x 8"     | 5-3/4      | 2     |
| NVS-2-70 | 4,500                 | 3,000            | 1/2"             | 5/8-11 x 8"     | 5-3/4      | 2     |
| NVS-3-50 | 10,000                | 6,700            | 5/8"             | 1-14 x 8"       | 9          | 2-3/8 |
| NVS-4-70 | 15,000                | 10,000           | 5/8"             | 1-14 x 8"       | 9          | 2-3/8 |
| NVS-5-50 | 25,000                | 16,700           | 3/4"             | 1-1/2 - 6 x 12" | 14         | 5-1/4 |
| NVS-6-70 | 40,000                | 25,000           | 3/4"             | 1-1/2 - 6 x 12" | 14         | 5-1/4 |

