

Assembly Procedure and Operating Instructions

ATTENTION: TO INSURE SAFE AND EASY USE OF YOUR WESCO PAIL TIPPER, READ THESE INSTRUCTIONS BEFORE USING.

This product is distributed by:

Wesco Industrial Products, Inc
1250 Welsh Road
North Wales, PA 19454
Tel: 215-699-7031 Fax: 215-699-3836

Contact the factory for parts information and ordering.
Visit us on the web at www.wescomfg.com

Unpacking

When unpacking the Wesco Product, check carefully for shipping damage and missing parts. If damage has occurred or any parts are missing, file a claim with the delivering carrier within 24 hours and notify the dealer from whom the unit was purchased.

Warranty Repairs

If the unit does not work properly, contact your dealer or the factory (215-699-7031) for units less than 90 days old.

Non-Warranty Service

If units are older than 90 days, repairs can be made easily on site with factory supplied parts.

NOTE: Do not send units to the factory for service without first obtaining a "Return Merchandise Authorization" (RMA) number from the customer service department. We will not be responsible for merchandise returned without proper authorization.

General Safety Information

Warning: The Wesco Pail Tipper is intended for specific functions. Please adhere to the following instructions to insure safe and proper use.

- (1) Maximum capacity - 70 Lbs.
- (2) Do not exceed rated capacity. Injury to persons or property may result from overloading and misuse.
- (3) **Only use on Plastic or Steel 5 Gallon Pails!**

Warning

- Use only for handling 5 gallon plastic or steel pails.
- Periodically check for loose or worn hardware; If found replace at once.

LIMITED WARRANTY

WESCO INDUSTRIAL PRODUCTS (WESCO) warrants to the purchaser of this product for a period of ninety (90) days from the date of purchase that this product shall be free of defects in material and/or workmanship, as follows:

1. WESCO will supply, at no charge, new or rebuilt replacements for any part that fails through a defect in material and/or workmanship during the warranty period. To obtain warranty service, you must deliver the product prepaid, to the WESCO factory.

2. This warranty does not cover any product or product part which has been subject to accident, misuse, abuse or negligence. WESCO shall only be liable under this warranty if the product is used in the manner intended by the manufacturer as specified in the written instructions furnished with this product.

REPAIR OR REPLACEMENT AS PROVIDED UNDER THIS WARRANTY IS THE EXCLUSIVE REMEDY OF THE PURCHASER. ANY EXPRESS WARRANTY NOT PROVIDED IN THIS WARRANTY DOCUMENT, AND ANY REMEDY FOR BREACH OF CONTRACT THAT, BUT FOR THIS PROVISION, MIGHT ARISE BY IMPLICATION OR OPERATION OF LAW, IS HEREBY EXCLUDED AND DISCLAIMED. UNDER NO CIRCUMSTANCES SHALL WESCO BE LIABLE TO PURCHASER OR ANY OTHER PERSON FOR ANY INCIDENTAL OR CONSEQUENTIAL DAMAGES, WHETHER ARISING OUT OF BREACH OF WARRANTY, EXPRESS OR IMPLIED, A BREACH OF CONTRACT OR OTHERWISE. EXCEPT TO THE EXTENT PROHIBITED BY APPLICABLE LAW, ANY IMPLIED WARRANTY OF MERCHANTABILITY AND FITNESS FOR ANY PARTICULAR PURPOSE ARE EXPRESSLY LIMITED IN DURATION TO THE DURATION OF THIS LIMITED WARRANTY.

Some states do not allow the exclusion or limitation of incidental or consequential damages, or allow limitations on how long any implied warranty lasts, so the above limitations may not apply to you. This warranty gives you specific legal rights, and you may also have other rights which vary from state to state.

Operating Instructions

- (1) Place the 5 gallon pail into the cradle
- (2) Place the locking arm on top of the pail and
- (3) Tighten the thumb screw. (The locking arm prevents the pail from falling out when tipped).
- (4) Use the tipping arm to rotate the pail
- (3) Release the locking arm to remove the pail

Tools Required

- [1] 11 mm Open End Wrench
- [1] 11 mm Box Wrench

Assembly Instructions

- (1) Secure the base of the tipper by applying the 11 mm hex bolts and locknuts at each of the six points labeled in Figure 1.
- (2) Slide the locking arm in to place, then secure with the thumb screw

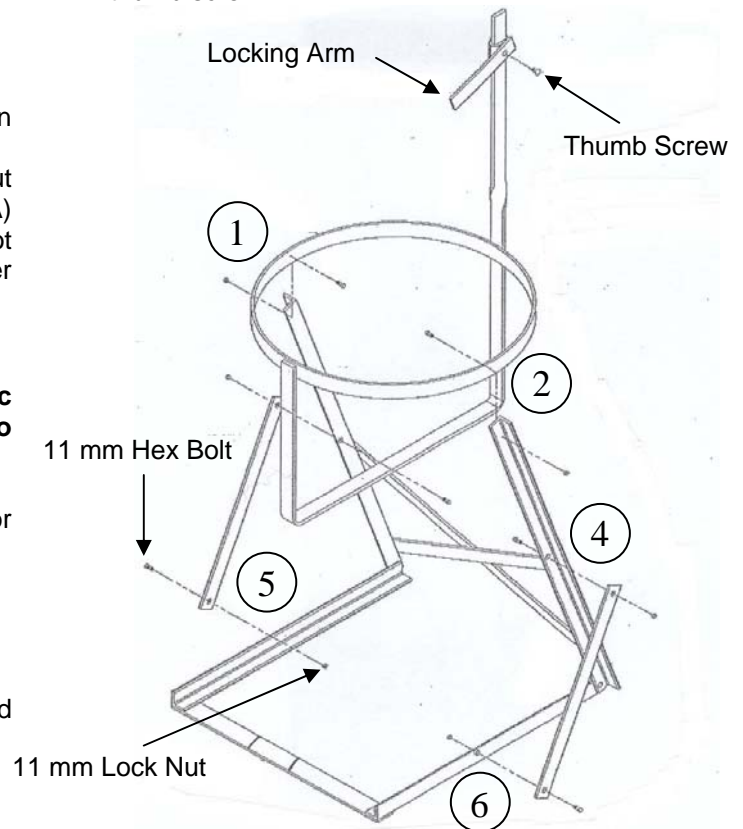

Figure 1