

Description

The Wesco Drip Pan is designed for installation on pumps with metal suction tube. It features a cast iron and steel construction, a hinged cover and a bung/suction adapter.

This product is distributed by:

Wesco Industrial Products, Inc

1250 Welsh Road

North Wales, PA 19454

Tel: 215-699-7031 Fax: 215-699-3836

Contact the factory for parts information and ordering.

Visit us on the web at www.wescomfg.com

Unpacking

When unpacking the Wesco Product, check carefully for shipping damage and missing parts. If damage has occurred or any parts are missing, file a claim with the delivering carrier within 24 hours and notify the dealer from whom the unit was purchased.

Warranty Repairs

If the unit does not work properly, contact your dealer or the factory (215-699-7031) for units less than 90 days old.



Figure 1

Spare Parts

Item	Part No.	Description
1	272211	Drip Pan (Optional)
2	272027	Bung Adapter

Drip Pan Assembly

- (1) Install the Drip Pan Coupling (A) to your drum.
- (2) Slide the Pump Suction Tube (B) through the Drip Pan Coupling into the drum leaving approximately 6-8 in. (153-204 mm) extended above the drum head as shown.
- (3) Tighten the Coupling screws (C) to hold the tube in place.
- (4) Screw the threaded Drip Pan Pipe into the Coupling.
- (5) Install the Drip Pan to the Drip Pan Pipe. Open the drip Pan Cover and your unit is ready for use.

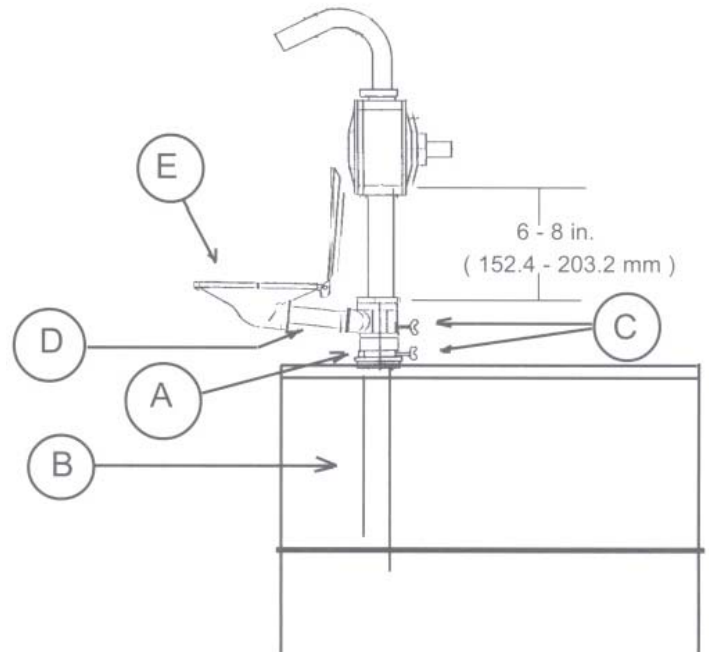

Figure 2

LIMITED WARRANTY

WESCO INDUSTRIAL PRODUCTS (WESCO) warrants to the purchaser of this product for a period of ninety (90) days from the date of purchase that this product shall be free of defects in material and/or workmanship, as follows:

1. WESCO will supply, at no charge, new or rebuilt replacements for any part that fails through a defect in material and/or workmanship during the warranty period. To obtain warranty service, you must deliver the product prepaid, to the WESCO factory.

2. This warranty does not cover any product or product part which has been subject to accident, misuse, abuse or negligence. WESCO shall only be liable under this warranty if the product is used the manner intended by the manufacturer as specified in the written instructions furnished with this product.

REPAIR OR REPLACEMENT AS PROVIDED UNDER THIS WARRANTY IS THE EXCLUSIVE REMEDY OF THE PURCHASER. ANY EXPRESS WARRANTY NOT PROVIDED IN THIS WARRANTY DOCUMENT, AND ANY REMEDY FOR BREACH OF CONTRACT THAT, BUT FOR THIS PROVISION, MIGHT ARISE BY IMPLICATION OR OPERATION OF LAW, IS HEREBY EXCLUDED AND DISCLAIMED. UNDER NO CIRCUMSTANCES SHALL WESCO BE LIABLE TO PURCHASER OR ANY OTHER PERSON FOR ANY INCIDENTAL OR CONSEQUENTIAL DAMAGES, WHETHER ARISING OUT OF BREACH OF WARRANTY, EXPRESS OR IMPLIED, A BREACH OF CONTRACT OR OTHERWISE. EXCEPT TO THE EXTENT PROHIBITED BY APPLICABLE LAW, ANY IMPLIED WARRANTY OF MERCHANTABILITY AND FITNESS FOR ANY PARTICULAR PURPOSE ARE EXPRESSLY LIMITED IN DURATION TO THE DURATION OF THIS LIMITED WARRANTY.

Some states do not allow the exclusion or limitation of incidental or consequential damages, or allow limitations on how long any implied warranty lasts, so the above limitations may not apply to you. This warranty gives you specific legal rights, and you may also have other rights which vary from state to state.